

BÖWE PASSAT

Ersatzteil- Katalog Spare Parts Catalogue

P 5.100

P 5.110

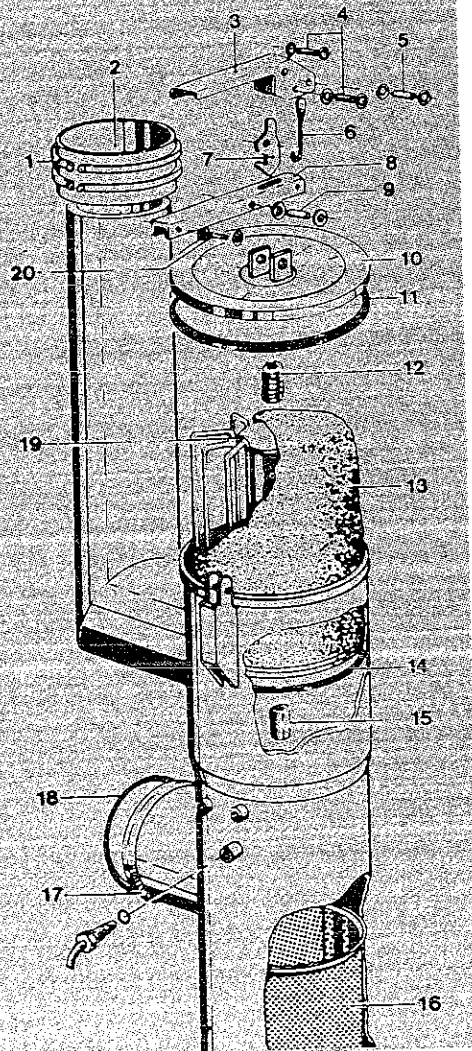

DIE FÜNFTE
GENERATION

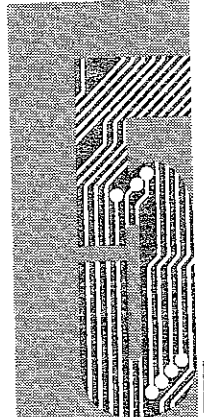

THE FIFTH
GENERATION

Der Inhalt entspricht unserem besten Wissen und basiert auf dem Stand der Technik. Rechtsverbindlichkeiten können nicht hergeleitet werden. Technische Änderungen vorbehalten. Nachdruck oder Vervielfältigung nur mit unserer ausdrücklichen Genehmigung.

The contents are correct to the best of our knowledge and belief and correspond to the present level of technology. No legal claims can be derived. Technical modifications reserved. Reproduction or duplication only with our express permission.

Cette documentation rédigée au mieux de nos connaissances, est basée sur le dernier standard de la technologie. Il ne saurait en résulter aucune responsabilité de notre part. Toute modification réservée. Toute reproduction interdite sauf notre autorisation expresse.

El contenido basa sobre la recién experiencia ganada en la tecnología. No asumimos responsabilidad alguna. Se reservan todos los derechos de modificación. Reproducción o multiplicación - sólo permitida con expresa autorización de la BÖWE.

ERSATZTEILKATALOG

SPARE PARTS CATALOGUE

CATALOGUE DE PIECES DE RECHANGE

CATALOGO DE REPUESTOS

P 5.100

P 5.110

BÖWE PASSAT

Reinigungs- und Wäschereitechnik GmbH

Postfach 10 13 80, D-86003 Augsburg

Telefon (0821) 570201, Fax (0821) 5702351, Tx 536480 boe d

WICHTIGE HINWEISE ZUR ERSATZTEIL-BESTELLUNG

Bei allen Ersatzteil-Bestellungen sind Maschinenbezeichnung, Fabrik-Nummer, Baujahr und Betriebsspannung anzugeben.

Die Bestellung der einzelnen Ersatzteile erfordert folgende Angaben: Stückzahl - Sachnummer - Bezeichnung.

Bei elektrischen Komponenten sind zusätzlich Spannung und Frequenz anzugeben.

Bestellbeispiel:

P 5.100, 102/9210, 400 V, 50 Hz

2 St. 202915 Flanschdichtung

1 St. 168747 Schütz 24 VDC

1 St. 203902 Motor Flansch 400 V, 50 Hz

Die im Ersatzteilkatalog mit Sachnummern angegebenen Ersatzteile sind normalerweise kurzfristig lieferbar.

Die mit einem * versehenen Sachnummern bezeichnen komplette Einheiten.

Das BÖWE-Werk arbeitet ständig an der Weiterentwicklung aller Produkte. Bitte haben Sie Verständnis dafür, daß wir uns daher jederzeit Änderungen des Lieferumfangs in Form, Ausstattung und Technik vorbehalten müssen. Aus den Angaben, Abbildungen und Beschreibungen des Ersatzteilkataloges können deshalb keine Ansprüche hergeleitet werden.

IMPORTANT POINTS TO NOTE WHEN ORDERING SPARE PARTS

In every spare parts order it is essential to state machine model, serial number, year of construction and operating voltage.

For the individual parts ordered the following data is needed: Quantity - part number (SN) - designation.

In the case of electrical components voltage and frequency must also be stated.

Example:

P 5.100, 102/9210, 400 V, 50 Hz

2 202915 flanged gasket

1 168747 contactor 24 VDC

1 203902 motor flanged 400 v. 50 Hz

The parts with a number (SN) in the catalogue are normally available at short notice.

The part numbers marked * refer to complete units.

At the BÖWE works we are constantly at work on the further development of all products. We are sure you will appreciate our need to reserve the right to change form, equipment and technology at any time. No liability can be derived from data, illustrations and descriptions in the spare parts catalogue.

AVIS IMPORTANT CONCERNANT LA COMMANDE DE PIÈCES DÉTACHÉES

Pour toute commande de pièces détachées, veuillez ne pas oublier d'indiquer le type de machine, le numéro et l'année de fabrication, ainsi que la tension de service.

La commande des diverses pièces détachées devra comprendre: nombre de pièces - no. de référence - désignation

Si vous commandez des composants électriques, indiquez en outre le voltage et la fréquence.

Exemple de bon de commande:

P 5.100, 102/9210, 400 V, 50 Hz

2 unités 202915 garniture d'étanchéité de bride

1 unité 168747 contacteur 24 VDC

1 unité 203902 moteur-bride 400 v. 50 Hz

Dans le catalogue, les pièces détachées suivies du no. de référence sont généralement livrables à court terme.

Les numéros de référence munis d'un astérisque (*) désignent des éléments complets.

L'usine BÖWE travaille continuellement au développement de ses fabrications.

Nous sommes persuadés que vous comprendrez que nous nous réservons, à tout moment, le droit de modifier l'étendue de la livraison dans sa forme, dans son équipement et son exécution technique.

De ce fait, nous ne pouvons prendre aucun engagement concernant les précisions, illustrations et descriptions données dans ce catalogue de pièces détachées.

AVISOS IMPORTANTES PARA PEDIDOS DE REPUESTOS

Al pedir repuestos hay que indicar la designación de la máquina, el número de fabricación, el año de fabricación, y la tensión de servicio.

Al pedir los diversos repuestos deberá indicarse el número de piezas, el número de referencia, y la designación.

Al pedir componentes electrónicos hay que indicar además la tensión y la frecuencia.

Ejemplo:

P 5.100, 102/9210, 400 V, 50 Hz

2 202915 Empaquetadura de brida

1 168747 Contactor 24 VDC

1 203902 Motor de brida 400 v. 50 Hz

Los repuestos marcados con números de referencia en el Catálogo de Repuestos normalmente pueden suministrarse rápidamente.

Los números de referencia marcados con * se refieren a unidades completas.

La fábrica BÖWE está trabajando constantemente en el desarrollo ulterior de todos sus productos.

Por esta razón, tenemos que reservarnos el derecho de modificar en cualquier momento el volumen de suministro respecto a su forma, equipamiento y tecnología.

Por consecuencia, no podemos asumir ninguna responsabilidad por los datos, las ilustraciones y las descripciones del Catálogo de Repuestos.

AVISO IMPORTANTE PER L'ORDINAZIONE DI PEZZI DI RICAMBIO

In tutte le ordinazioni di pezzi di ricambio è assolutamente necessario indicare il modello di macchina, il numero di macchina, l'anno di costruzione ed il voltaggio d'esercizio.

Sempre per l'ordinazione di pezzi di ricambio occorrono numero di pezzi - numero SN - modello di macchina.

Bisogna precisare ancora la tensione e la frequenza dei componenti elettrici da ordinare.

Esempio di ordinazione:

P 5.100, 102/9210, 400 V, 50 Hz

2 pezzi 202915 guarnizione a flangia
1 pezzo 168747 reità 24 VDC
1 pezzo 203902 motore flangia 400 v. 50 hz

I pezzi di ricambio muniti di numero nel catalogo dei pezzi di ricambio sono normalmente apronta consegna.

I numeri di pezzi dotati di * designano gli organi completi.

ricambio.

La BÖWE provvedere continuamente all'ulteriore sviluppo di tutti i prodotti. Abbia, quindi, della comprensione se dobbiamo perciò riservarci il diritto di modifica della fornitura, per quanto riguarda la forma, la dotazione di accessori e la tecnologia.

Dai dati, dalle illustrazioni e dalle descrizioni di cui al catalogo dei pezzi di ricambio non possono quindi derivare diritti di sorta.

DŮLEŽITÁ UPOZORNĚNÍ TÝKAJÍCÍ SE OBJEDNÁVEK NÁHRADNÍCH DÍLŮ

Při všech objednávkách náhradních dílů uvádějte typové označení, výrobní číslo, rok výroby, provozní napětí.

Při objednávkách jednotlivých náhradních dílů jsou nutně následující údaje: počet - č. výrobku - označení.

Při elektrických komponentech je nutno navíc uvést napětí a frekvenci.

Příklad objednávky:

P 5.100, 102/9210, 400 V, 50 Hz

2 kusy 202915 těsnění přírub
1 kus 168747 pomocný stykač 24 VDC
1 kus 203902 odstředivací motor 400 V, 50 Hz

Náhradní díly označené v katalogu číselm jsou dodávány obvykle v krátké lhůtě.

Hvězdičkou označená čísla náhradních dílů označují kompletní celky. *

Podnik BÖWE nepřetržitě pracuje na dalším vývoji všech svých výrobků. Proto Vás prosíme o pochopení při případných změnách ohledně rozsahu, tvaru, vybavení a techniky.

Z údajů, vyobrazení a popisu v katalogu náhradních dílů nelze vyvozovat žádné nároky.

ВАЖНЫЕ УКАЗАНИЯ ДЛЯ ЗАКАЗА ЗАПЧАСТЕЙ

При заказе запчастей указание названия машины, номера машины, года изготовления и напряжения тока всегда необходимо.

При заказе отдельных запчастей необходимо указание следующих: количество, номер части, наименование.

При электрических компонентах обязательно указать тоже напряжение и частоту.

Пример заказа:

П 5.100, 102/9210, 400 V, 50 Hz

2 шт. 202915 уплотнение
1 шт. 168747 вспомогательный контактор 24 VDC
1 шт. 203902 двигатель центрифугования 400 в, 50 гц

Нумерованные запчасти нормально поставляются краткосрочно.

* Так обозначенные в каталоге номера показывают комплектные узлы.

Завод БЭВЕ постоянно работает над дальнейшим развитием всей продукции. Поэтому поймите пожалуйста, что мы в любое время можем оставить за собой право изменить объём поставки по форме, виду и технике.

Из данных, рисунков и описаний каталога запчастей поэтому нельзя выводить каких-либо требований.

WAŻNE WSKAZÓWKI DO ZAMAWIANIA CZĘŚCI ZAMIENNYCH

Przy każdym zamówieniu części zamiennych należy podać rodzaj maszyny, numer fabryczny, rok budowy i natężenie zakładowe.

Przy zamawianiu poszczególnych części zamiennych należy podać następujące dane: ilość, numer części oznaczenie.

Przy składnikach elektrycznych należy dodatkowo podać natężenie i frekwencję.

Przykład zamówienia:

P 5.100, 102/9210, 400 V, 50 Hz

2 sztuki 202915 uszczelnienie kołnierzone
1 sztuka 168747 ochrona pomocnicza 24 VDC
1 sztuka 203902 motor wirówki 400 v. 50 Hz

Części zamienne oznaczone w katalogu części zamiennych numerem części mogą być dostarczone natychmiast.

Numerы części oznaczone znakiem * oznaczają pełne zestawy.

Firma BÖWE pracuje ciągle nad ulepszeniem wszystkich produktów. W związku z tym prosimy o zrozumienie, że w każdej chwili możemy zmienić formę, wyposażenie lub stan techniczny zamówienia. Z zamieszczonych w katalogu części zamiennych danych, opisów i rysunków nie mogą być wysuwane żadne roszczenia.

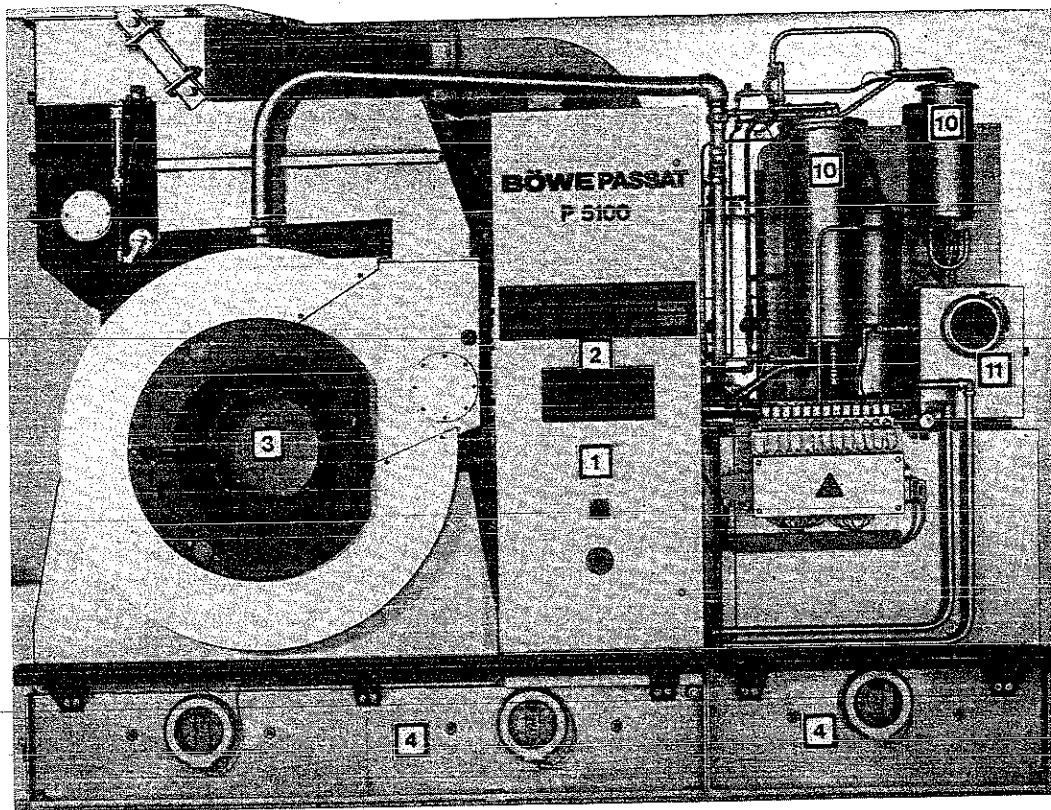

1. VERKLEIDUNG	PANELLING	HABILLAGE	REVESTIMIENTO
2. ELT. STEUERUNG	ELEC. CONTROL	ARMOIRE ELECTRIQUE	MANDO ELECTRICO
3. LADETÜR	LOADING DOOR	HUBLOT	PUERTA DE CARGA
4. TANK	TANK	RESERVOIR	DEPOSITO
5. TROMMEL MIT GEHÄUSE TROMMELLAGER	CAGE WITH HOUSING CAGE BEARING	TAMBOUR AVEC CARTER PALIER DE TAMBOUR	TAMBOR CON SU CARTER COJINETE TAMBOR
6. DESTILLIERBEHÄLTER D 564 DESTILLIERBEHÄLTER D 5.100 HAND-DOSIERPUMPE (DESTILLATION)	STILL D 564 STILL D 5.100 MANUAL DOSING PUMP (STILL)	ALAMBIC D 564 ALAMBIC D 5.100 REPLISSAGE SOLVANT POMPE DE DOSAGE A MAIN (ALAMBIC)	DESTILADOR D 564 DESTILADOR D 5.100 DISOLVENTE BOMBA DOSIFICADORA A MANO (DESTILADOR)
7. LUFTFÜHRUNGSSCHACHT LADETÜRBELÜFTUNG	RECOVERY SECTION LOADING DOOR VENTING	TUNNEL DE RECUPERATION EXTRACTEUR-VENTILTEUR	TUNEL AIRE VENTILACION DE LA PUERTA DE CARGA
8. ÖKO-FILTER 35/50	ECO-FILTER 35/50	FILTRE-ÖKO 35/50	FILTRO-ÖKO 35/50
9. NADELFÄNGER SELBSTREINIGENDER NADELFÄNGER PUMPE	BUTTON TRAP SELF-CLEANING BUTTON TRAP PUMP	FILTRE A EPINGLES FILTRE A EPINGLES AUTO-NETTOYANT POMPE	CAZA-BOTONES CAZA-BOTONES AUTOPURIFICADOS BOMBA
10. KONDENSATOR D 564 KONDENSATOR D 5.100	CONDENSER D 564 CONDENSER D 5.100	CONDENSEUR D 564 CONDENSEUR D 5.100	CONDENSADOR D 564 CONDENSADOR D 5.100

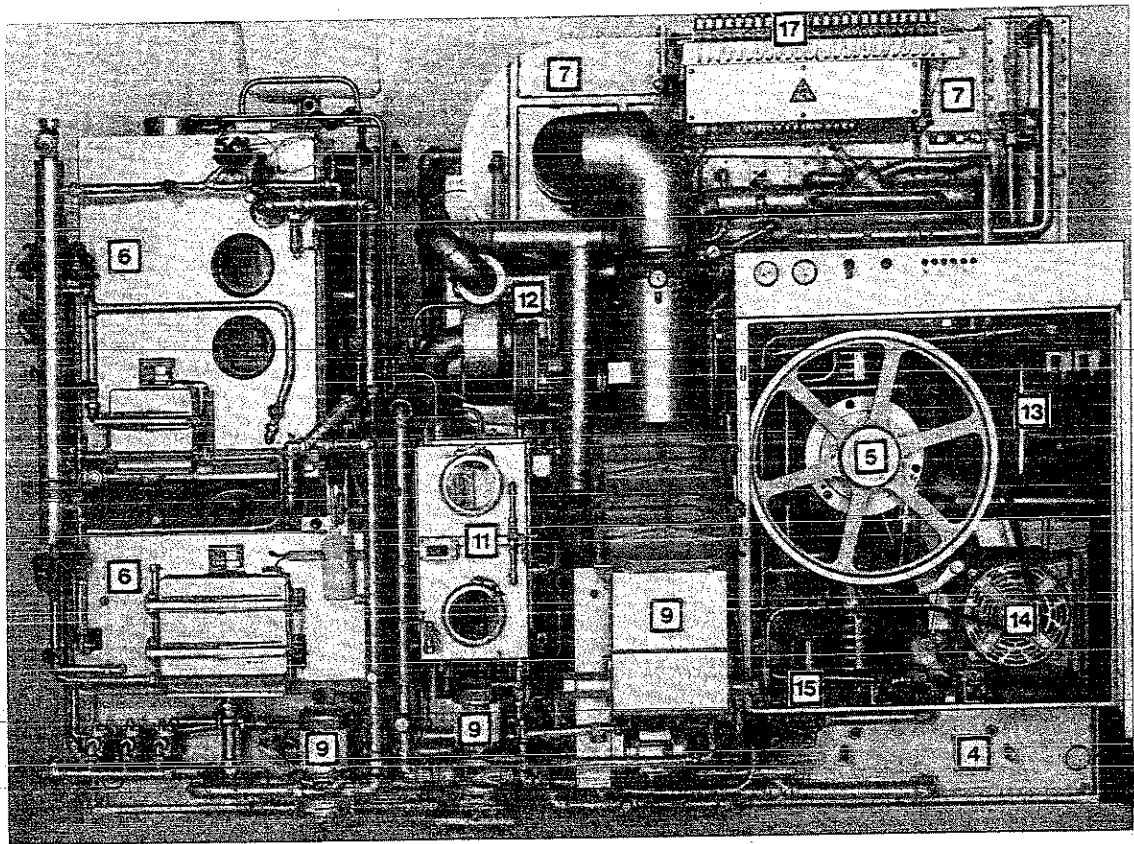

11. WASSERABSCHIEDER
MIT DRYSTAT
LÖSEMITTELAUFFÜLLUNG

WATER SEPARATOR WITH
DRYSTAT
SOLVENT FILLING

SEPARATEUR D'EAU
AVEC
DRYSTAT

SEPARADOR AGUA CON
DRYSTAT
RELLENO DE

12. CONSORBA

CONSORBA

CONSORBA

CONSORBA

13. KÄLTEAGGREGAT

REFRIGERATION UNIT

GROUPE FRIGORIFIQUE

GRUPO DE
REFRIGERACION

14. ENTSORGUNG -
EMISSIONSFREI
ANTRIEB

EMISSION-FREE
REMOVAL OF STILL
RESIDUES
DRIVE

EVACUATION DES
DECHETS SANS
EMISSION
MOTEURS

EVACUATIONE DEI
RESIDUI SANZA-
EMISSIONE
IMPULSION

15. DOSIERGERÄT
ZUBEHÖR

DOSING UNIT
ACCESSORIES

DOSEUR
ACCESSOIRES

DOSIFICADOR
ACCESORIOS

16. WARTUNGSEINHEIT
KÜHLWASSERREGLER

COMPRESSED AIR
MAINTENANCE
COOLING WATER REGULATOR

GROUPE D'ENTRETIEN
PNEUMATIQUE
VANNE THERMOSTATIQUE
D'EAU DE REFROIDISSEMENT

UNIDAD DE MANTENIMIENTO
DEL SISTEMA PNEUMATICO
REGULADOR DEL AGUA
REFRIGERANTE

17. VENTILE

VALVES

VANNES

VALVULAS

18. SCHAUGLÄSER
KONDENSATABLEITER

SIGHT-GLASSES
STEAM TRAP

VOYANTS
CONDENSATEUR

MIRILLAS
SEPERATORE DI CONDENSA

19. VERSCHRAUBUNGEN

SCREWED UNIONS

UNIONS VISSEES

UNIONES



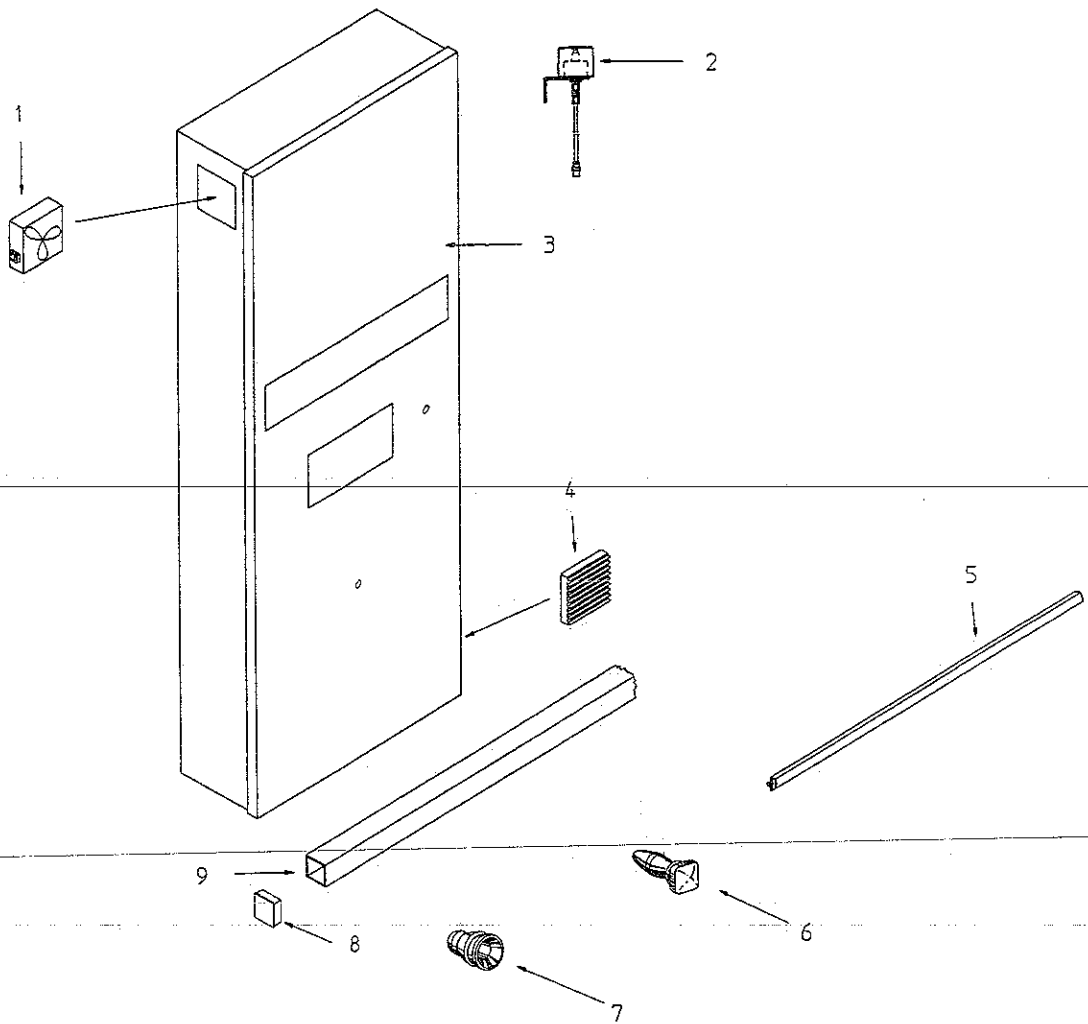

POS. ITEM	BESTELLNUMMER PART NUMBER	BENENNUNG DESIGNATION
1	209464	VENTILATOR FAN
2	197137	DRUCKSCHALTER PRESSURE SWITCH
3	208716	SCHALTSCHRANKTÜR PANEL
4	209465	LUFTFILTER AIR STRAINER
5	206972	PROFILSTOSSLEISTE PROTECTIVE PROFILE STRIP
6	014773	STOPFEN FÜR ZIERLEISTE DECORATIVE STRIP PIN
7	014774	TÜLLE DECORATIVE STRIP STUD
8	087011	STOPFEN STOPPER
9	206974	SCHIENE TRACK



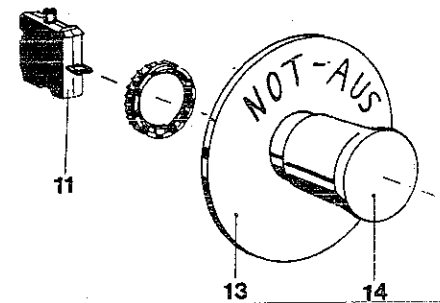
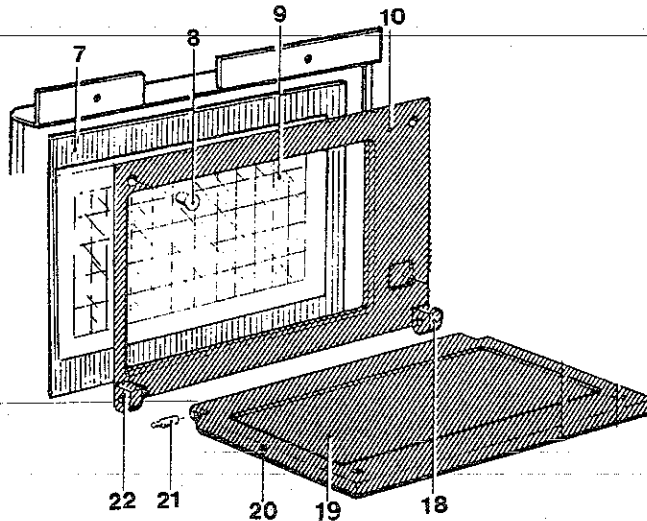
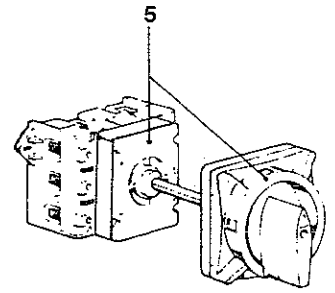
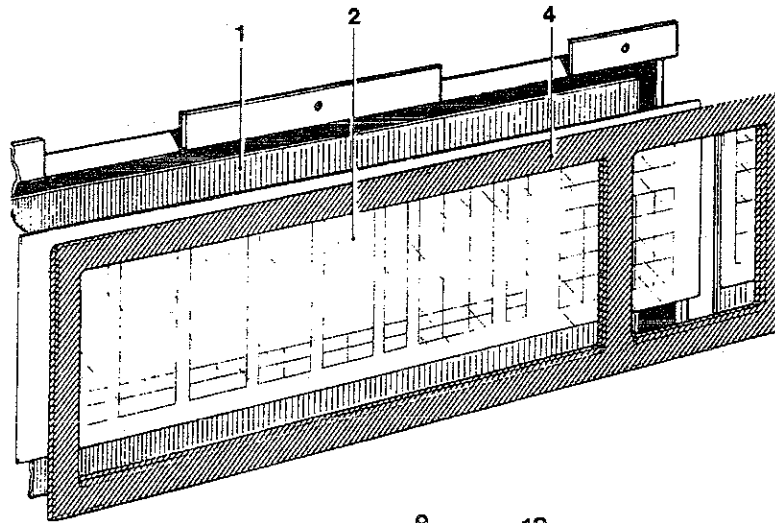

POS. ITEM	BESTELLNUMMER PART NUMBER	BENENNUNG DESIGNATION
1	190625	LEITERPLATTE CAP FOR CIRCUIT BOARD
2	164315	KLEBEFOLIE BEDIENUNG OPERATING FOIL
4	013122	BLENDE PANEL
5	190285	HAUPTSCHALTER MAIN SWITCH
7	163668	BAUTEILETRÄGER PROG.-TEIL PROG. P. COMP. CARRIER
8	159823	MAGNETVERSCHLUSS MAGN. LOCK
9	191578	KLEBEFOLIE PROGR. PROGRAM FOIL
10	168188	BLENDE PANEL

POS. ITEM	BESTELLNUMMER PART NUMBER	BENENNUNG DESIGNATION
11	700582	SCHALTELEMENT CONTACT ELEMENT
13	700749	SCHILD NOT-AUS LABEL
14	700750	DRUCKTASTER PRESSURE SWITCH
18	134808	SCHARNIER RECHTS HINGE
19	164256	SCHILD PROGR.-ÜBERSICHT LABEL PROGR. REVIEW
20	134804	DECKEL LID
21	134809	WELLE DECKELLAGER LID. BEAR. SHAFT
22	134807	SCHARNIER LINKS HINGE

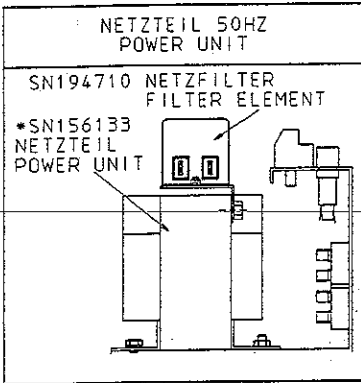
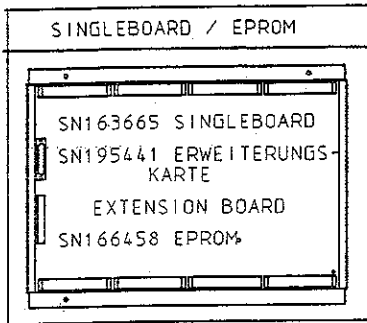

SICHERUNGEN
FUSE SX20TR

I	SN
0.5	086691
0.63	083610
0.8	002040
1.0	000118
1.25	050026
2.0	000119
2.5	028504
3.15	000121
4.0	000122
6.3	000125
8.0	033053

9 MOTORSCHUTZSCHALTER
MOTOR CONTROLLER
PKZM1

I	SN
0.24-0.4	164760
0.4-0.6	164761
0.6-1.0	164765
1.0-1.6	164569
1.6-2.4	159933
2.4-4.0	159934
4.0-6.0	160880
6.0-10.0	164570
10.0-16.0	164921
16.0-20.0	193002
20.0-25.0	164762

HILFSKONTAKT
AUX. CONTACT

TYP	SN
NH111	164775
RH101	164454

11 MOTORSCHUTZSCHALTER
MOTOR CONTROLLER
PKZ2

TYP	SN
ZM32	021243
ZM40	201846

HILFSKONTAKT
AUX. CONTACT

TYP	SN
AGM2-11	025233

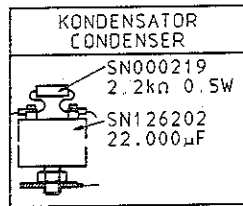

SI-AUTOMATEN
CIRCUIT BREAKER

I	SN
3A	001121
6A	195641
10A	000678
16A	000733
20A	195642
25A	195643

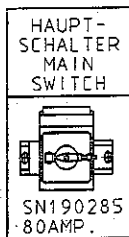
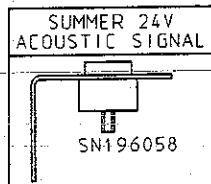

2 SCHUETZE 2
CONTACTOR

TYPE	SN
BC6-30-10	159063
BC9-30-10	159064
BC16-30-10	159065
BC25-30-10	163670
BC30-30-00	168747
KC6-40	161270
VBC6-3002Z	161348
K22E	125666

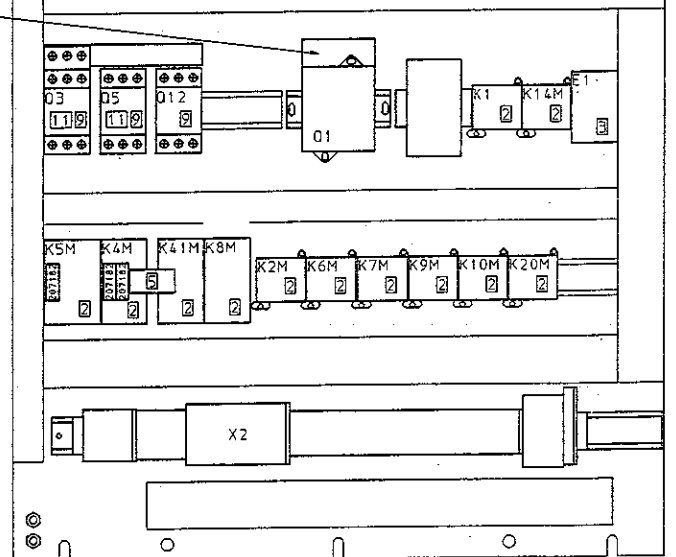
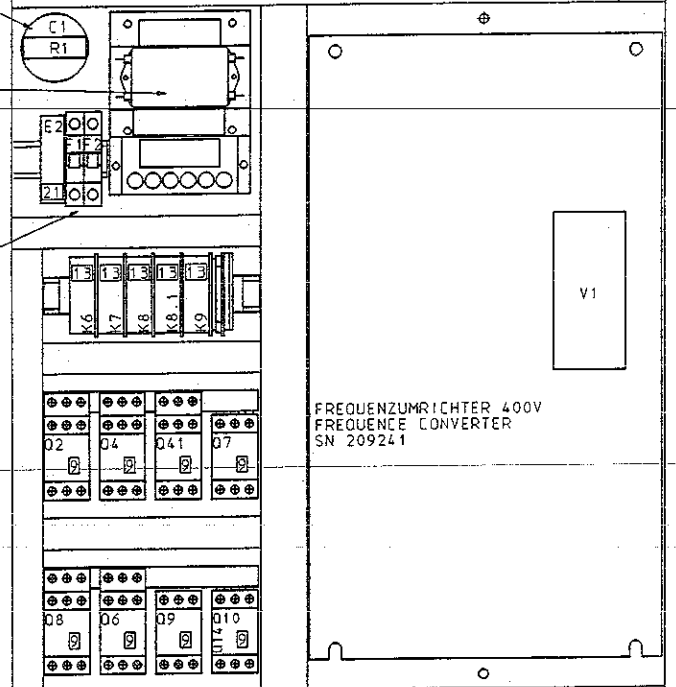
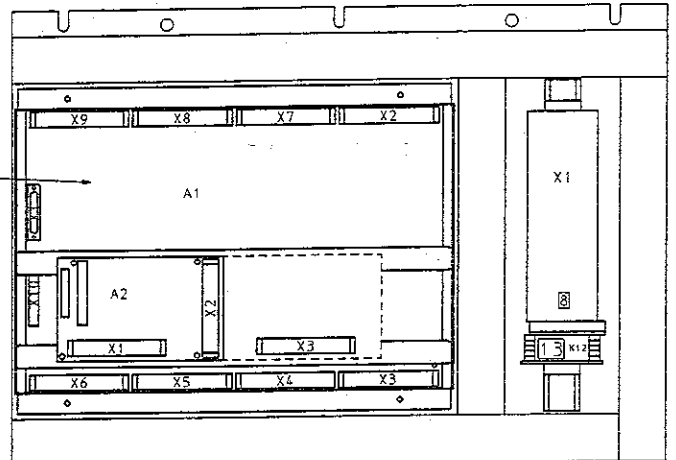
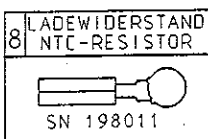
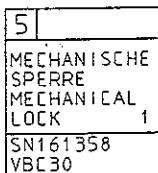

13 RELAISE

TYP	SN
25-20	200497
3S-10	200498

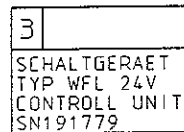

21 THERMISTOR
MOTORSCHUTZ
MOTORPROTECTOR

CUSTOMAPID
C105.02
SN164763

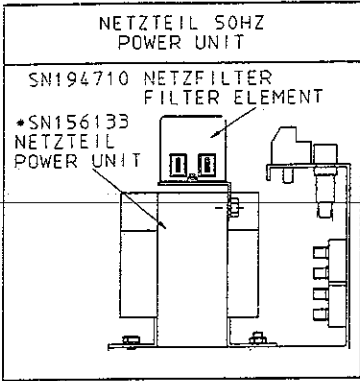
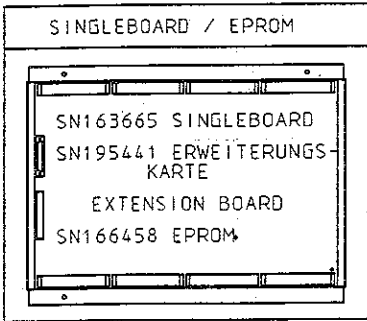

9 MOTORSCHUTZSCHALTER
MOTOR CONTROLLER
PKZM1

I	SN
0.24-0.4	164760
0.4-0.6	164761
0.6-1.0	164765
1.0-1.6	164569
1.6-2.4	159933
2.4-4.0	159934
4.0-6.0	160880
6.0-10.0	164570
10.0-16.0	164921
16.0-20.0	193002
20.0-25.0	164762

HILFSKONTAKT
AUX. CONTACT

TYP	SN
NH111	164775
RH101	164454

SICHERUNGEN
FUZE SX20TR

I	SN
0.5	086691
0.63	083610
0.8	002040
1.0	000118
1.25	050026
2.0	000119
2.5	028504
3.15	000121
4.0	000122
6.3	000125
8.0	033053

11 MOTORSCHUTZSCHALTER
MOTOR CONTROLLER
PKZ2

TYP	SN
ZM32	021243
ZM40	201846

HILFSKONTAKT
AUX. CONTACT

TYP	SN
AGM2-11	025233

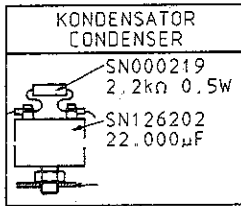

S1-AUTOMATEN
CIRCUIT BREAKER

I	SN
3A	001121
6A	195641
10A	000678
16A	000733
20A	195642
25A	195643

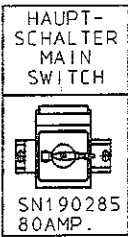
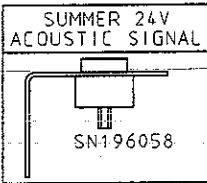

2 SCHUETZE 2
CONTACTOR

TYPE	SN
BC6-30-10	159063
BC9-30-10	159064
BC16-30-10	159065
BC25-30-10	163670
BC30-30-00	168747
KC6-40	161270
VBC6-3002Z	161348
K22E	125666

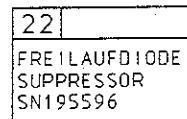
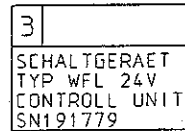
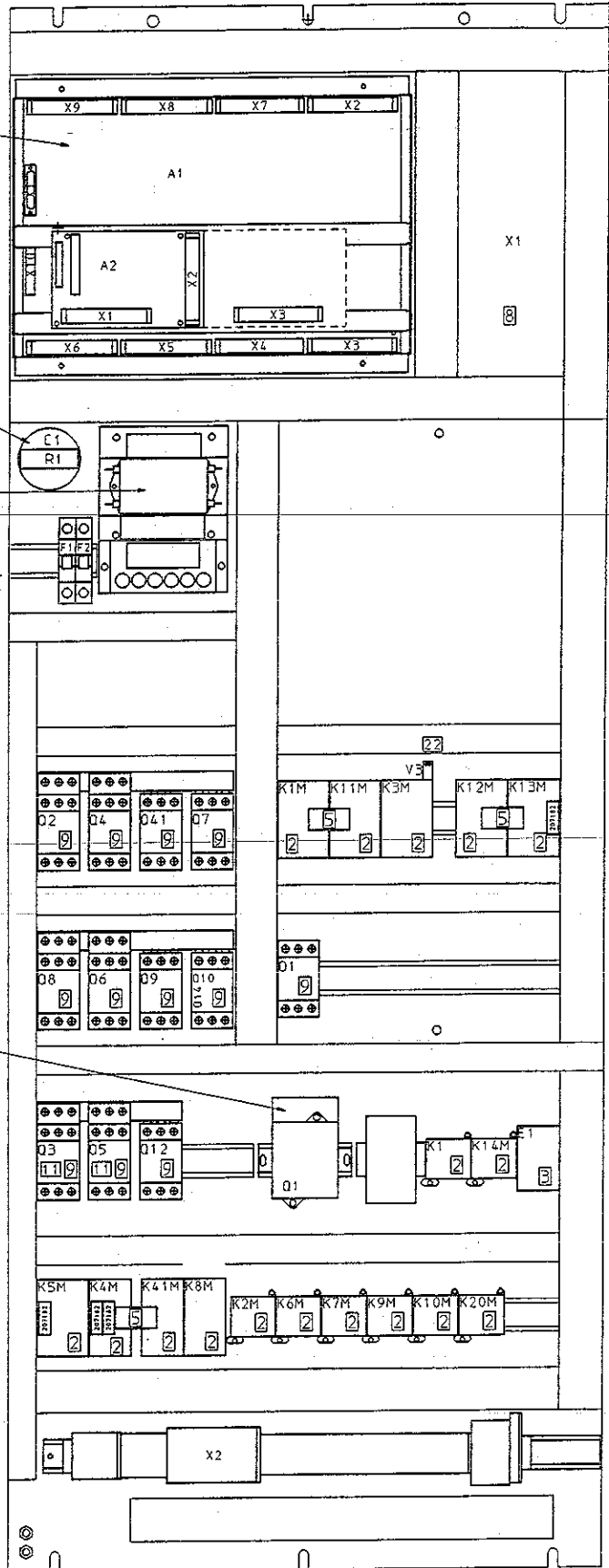
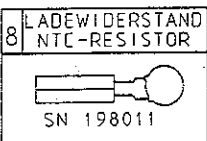
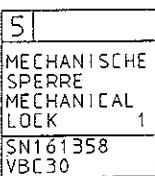



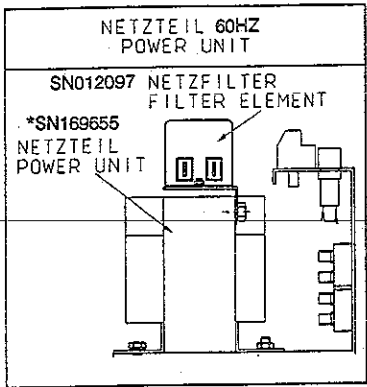
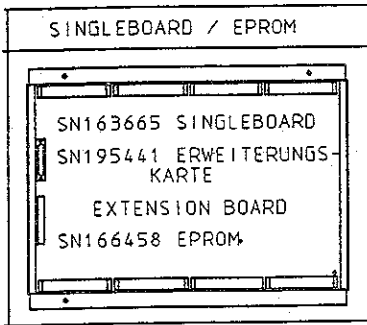

SICHERUNGEN
FUSE 5X20TR

I	SN
0.5	086691
0.63	083610
0.8	002040
1.0	000118
1.25	050026
2.0	000119
2.5	028504
3.15	000121
4.0	000122
6.3	000125
8.0	033053

9 MOTORSCHUTZSCHALTER
MOTOR CONTROLLER
PKZM1

I	SN
0,24-0,4	164760
0,4-0,6	164761
0,6-1,0	164765
1,0-1,6	164569
1,6-2,4	159933
2,4-4,0	159934
4,0-6,0	160880
6,0-10,0	164570
10,0-16,0	164921
16,0-20,0	193002
20,0-25,0	164762

HILFSKONTAKT
AUX. CONTACT

TYP	SN
NH111	164775
RH101	164454

11 MOTORSCHUTZSCHALTER
MOTOR CONTROLLER
PKZ2

TYP	SN
ZM32	021243
ZM40	201846

HILFSKONTAKT
AUX. CONTACT

TYP	SN
AGM2-11	025233

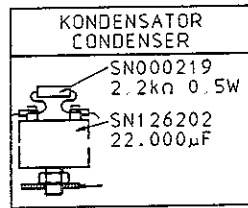

S1-AUTOMATEN
CIRCUIT BREAKER

I	SN
3A	001121
6A	195641
10A	000678
16A	000733
20A	195642
25A	195643

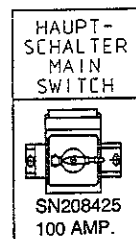
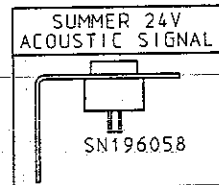

2 SCHUETZE 2
CONTACTOR

TYPE	SN
BC6-30-10	159063
BC9-30-10	159064
BC16-30-10	159065
BC25-30-10	163670
BC30-30-00	168747
KC6-40	161270
VBC6-3002Z	161348
K22E	125666

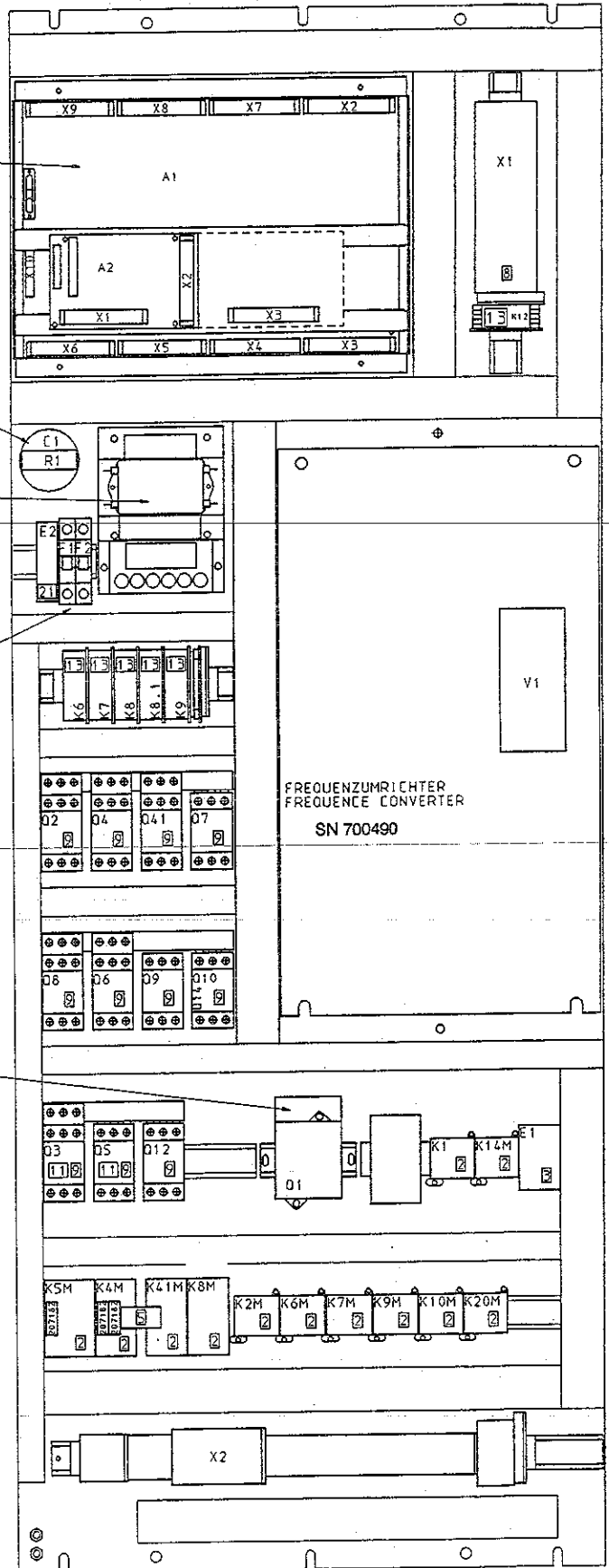
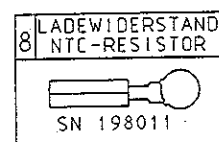
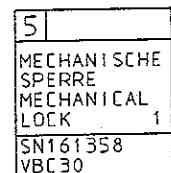

13 RELAISE

TYP	SN
25-20	200497
35-10	200498

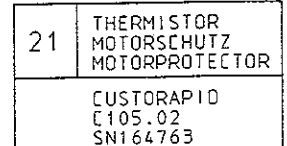
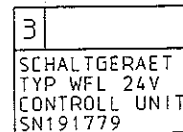

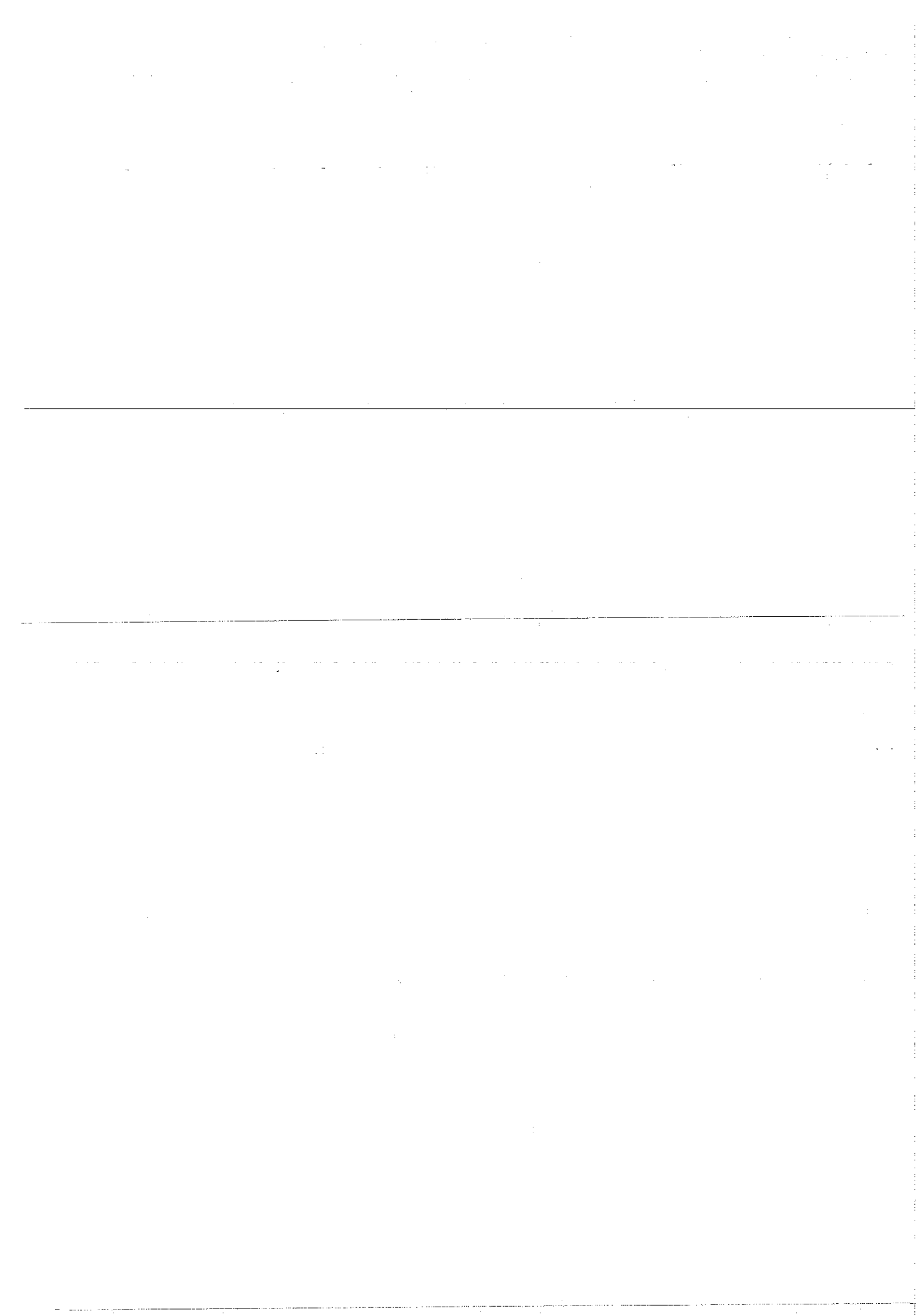

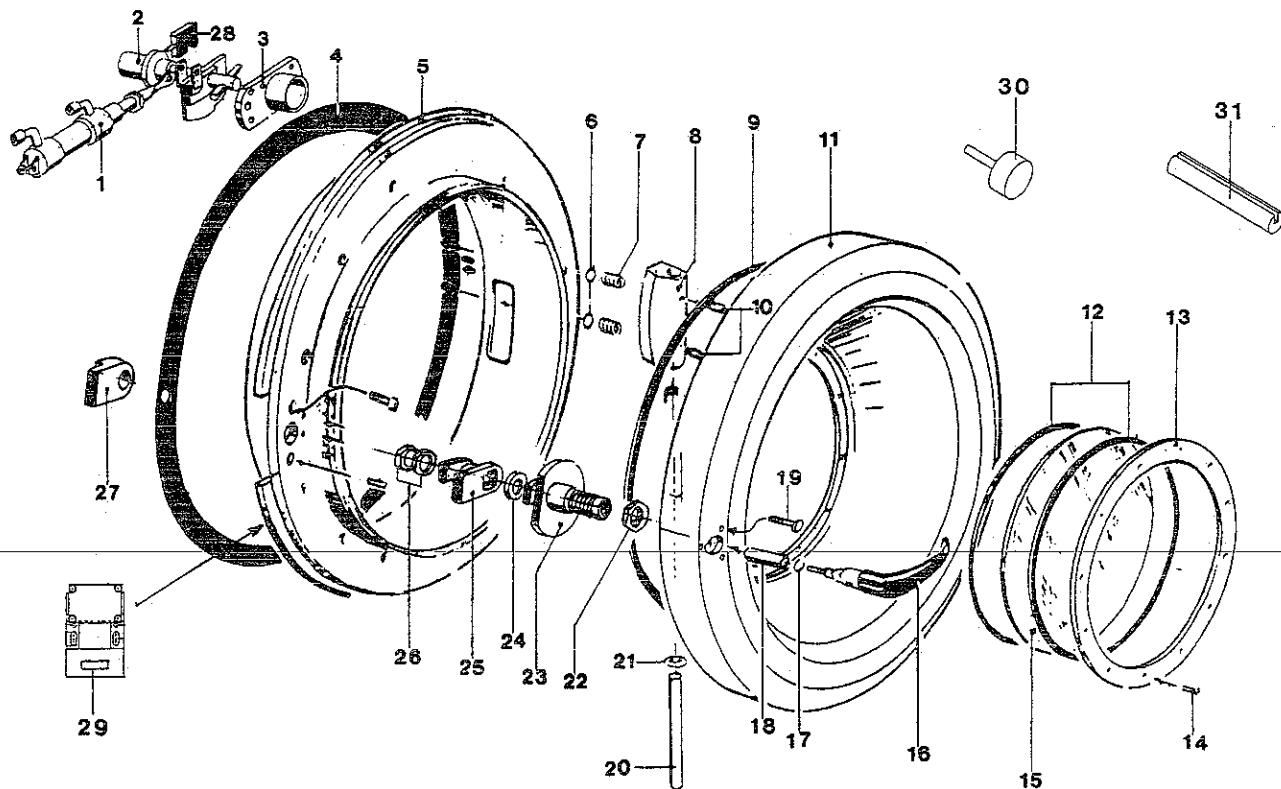

POS. ITEM	BESTELLNUMMER PART NUMBER	BENENNUNG DESIGNATION	POS. ITEM	BESTELLNUMMER PART NUMBER	BENENNUNG DESIGNATION
1	125668	ZYLINDER CYLINDER	17	126903	FEDERSCHEIBE GEWELLT SPRING WASHER
2	194771	SPINDEL KOMPLETT SPINDLE COMPL.	18	194785	DISTANZHÜLSE DISTANCE SLEEVE
3	004086	SPANNBUCHSE ADAPTER SLEEVE	19	195922	SCHRAUBE FL.-ZYL. HEXAGON NUT
4	194778	FLANSCHDICHTUNG GASKET FLANGE	20	194772	SCHARNIER-BOLZEN HINGE BLOCK
5	198132	LADETÜRRAHMEN FRAME LOADING DOOR	21	194807	STOPFEN LOCKING PLUG
6	195361	SCHEIBE WASHER	22	195924	NUTMUTTER NUT
7	021983	DRUCKFEDER PRESSURE SPRING	23	194784	FÜHRUNGSBUCHSE FAIRLEAD BUSH
8	194774	SCHARNIERKLOTZ HINGE BLOCK	24	100680	SCHEIBE WASHER
9	025404	PROFILDICHTRING GASKET	25	003948	VERSCHLUSSRIEGEL LOCKING LATCH
10	197353	GEWINDESTIFT MIT ZAPPEN THREADED PIN	26	003793	MUTTER 6KT. FLACH HEXAGON NUT
11	198156	TÜR DOOR	27	194894	LADETÜRANSCHLAG STOP LOADING DOOR
12	038627	DICHTRING GASKET	28	169930	SCHALTER SWITCH
13	118670	LADETÜRFLANSCH FLANGE LOADING DOOR	29	195409	SCHALTER SWITCH
14	003286	SENKSCHRAUBE CK-SCREW	30	086390	PUFFER BUFFER
15	038628	GLASSCHEIBE GLASS ONLY	31	161426	SCHNUR RUND ROUND CORD
16	194766	LADETÜRGRIFF HANDLE			

POS. ITEM	BESTELLNUMMER PART NUMBER	BENENNUNG DESIGNATION	POS. ITEM	BESTELLNUMMER PART NUMBER	BENENNUNG DESIGNATION
1	202597	TANK I + III TANK I + III	17	203907	REINTANK KOMPLETT FÜR DESTILLATION SN 206400 CLEAN TANK COMPLETE FOR STILL SN 206400
1a	700377	TANK I + III TANK I + III	18	700881	SKALA 160 - 400 L SCALE
2	166339	DECKEL LID	19	700880	SKALA 440 - 680 L SCALE
3	134401	DICHTUNG GASKET	20	000907	GEWINDESTIFT MIT SPITZE THREADED PIN
4	031939	SCHMUTZFÄNGER 3/4" STRAINER	21	115947	SCHAUGLASRAHMEN FRAME
5	016036	GEGENMUTTER HEXAGON NUT	22	195078	RING RING
6	014075	DICHTSCHEIBE GASKET	23	144097	PROFILDICHTRING STILL S. GLASS SEAL
7	195243	KÜHLERSCHLANGE COOLING COIL	24	144137	GLASSSCHEIBE GLASS PANE
8	202633	REINTANK - VERZINKT CLEAN TANK - GALVANIZED	25	206931	SCHAUGLAS-SICHTBLENDE SCREEN FOR SIGHTGLASS
9	209158	HALTERUNG-ANODE HOLDER-ANODE	26	209157	HALTERUNG SICHTBLENDE SCREEN HOLDER
10	054524	ANODE ANODE	27	208847	SKALA 240 L SCALE
11	208849	SKALA 320 L SCALE	28	013211	SCHWIMMER FLOAT
12	086347	MUTTER 1 1/4" NUT	29	195500	HALTER HOLDER
13	049378	DICHTUNG-PERBUNAN GASKET	30	155793	HALOGENGLÜHLAMPE LAMP
14	207120	DECKEL LID	31	155792	LAMPENFASSUNG LAMP HOLDER
15	207119	DICHTUNG GASKET	32	003802	MUTTER 6KT. NUT
16	206961	KÜHLERSCHLANGE COOLING COIL	33	000752	ZYLINDERSCHRAUBE M3 SCREW

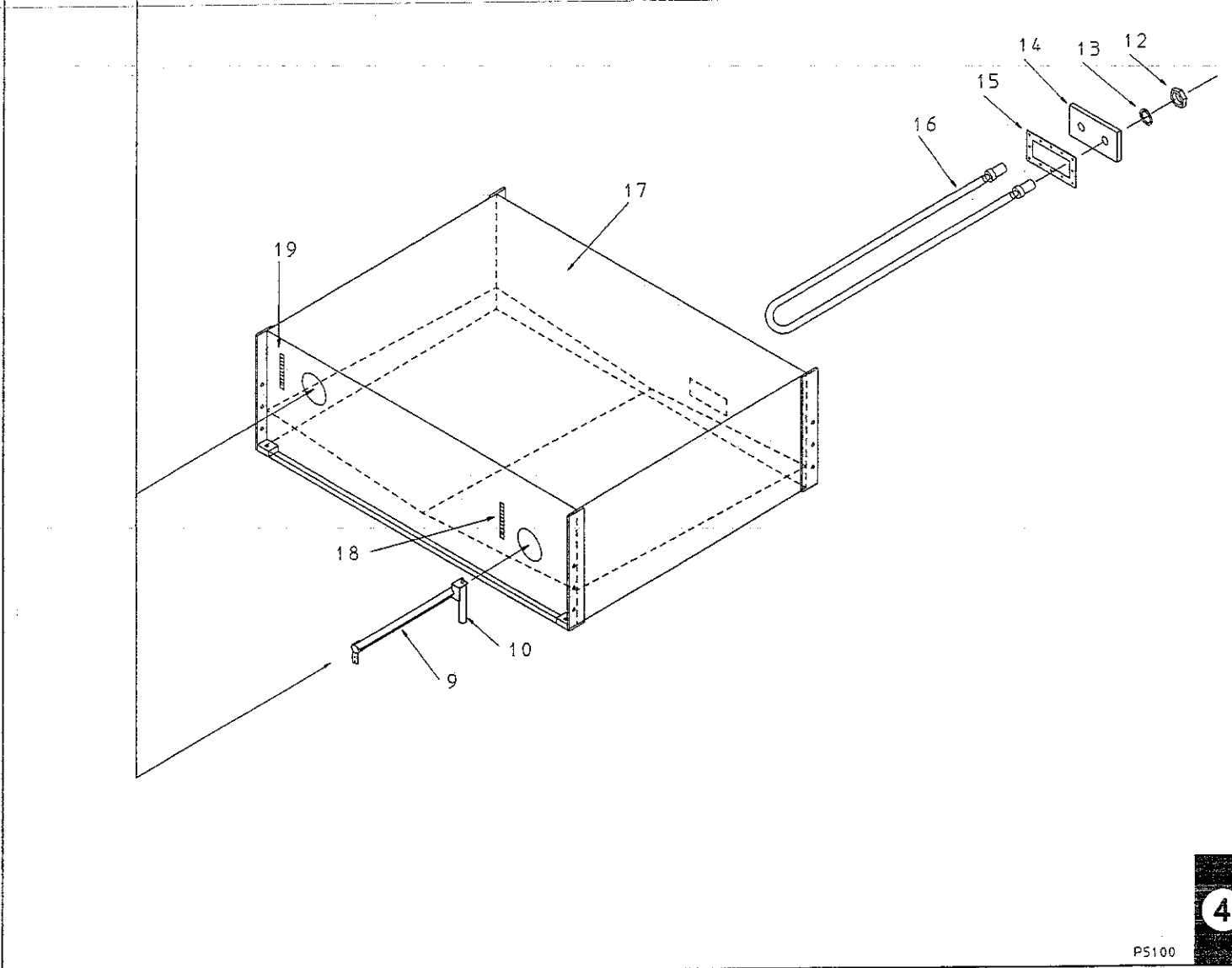
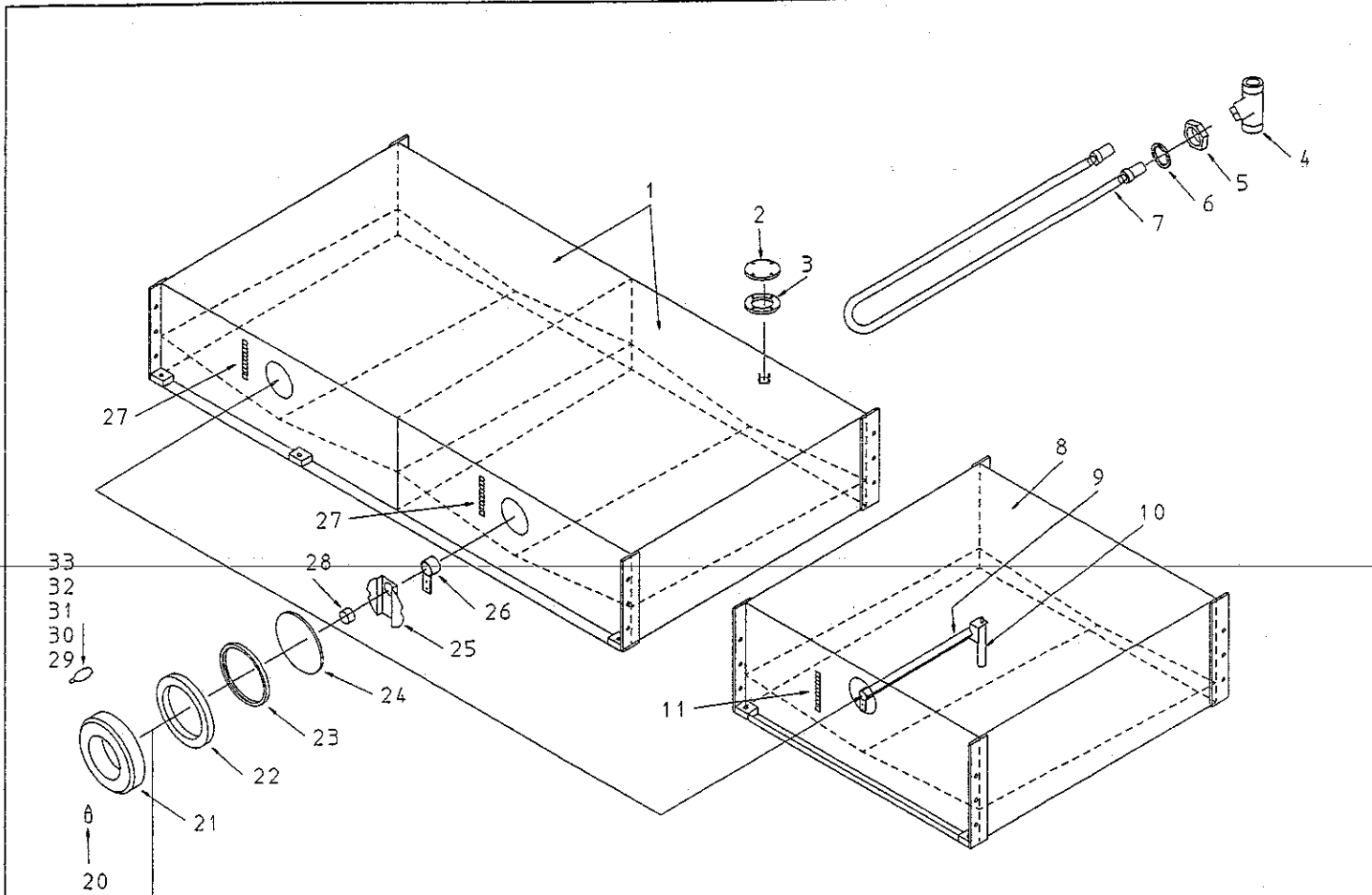

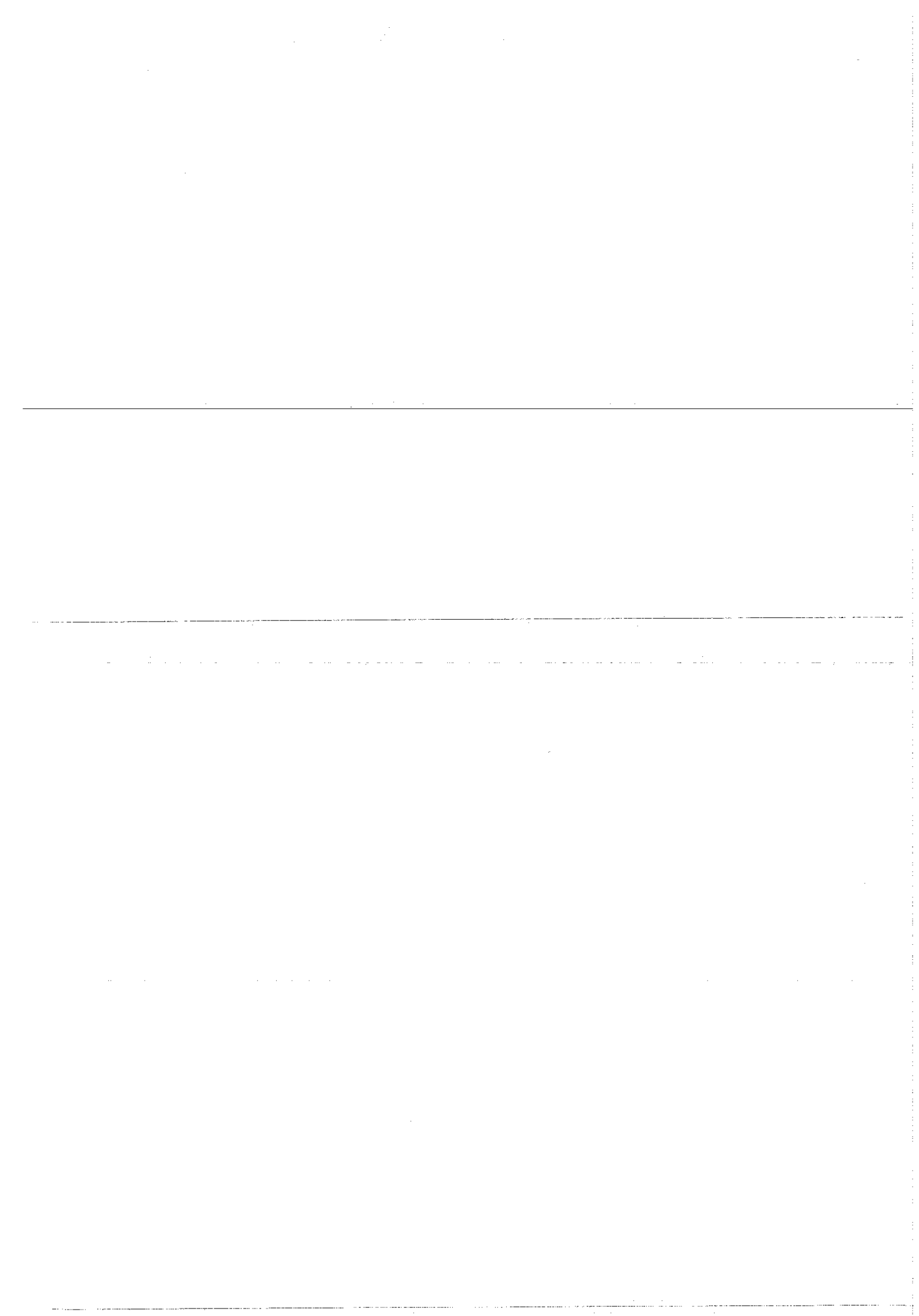

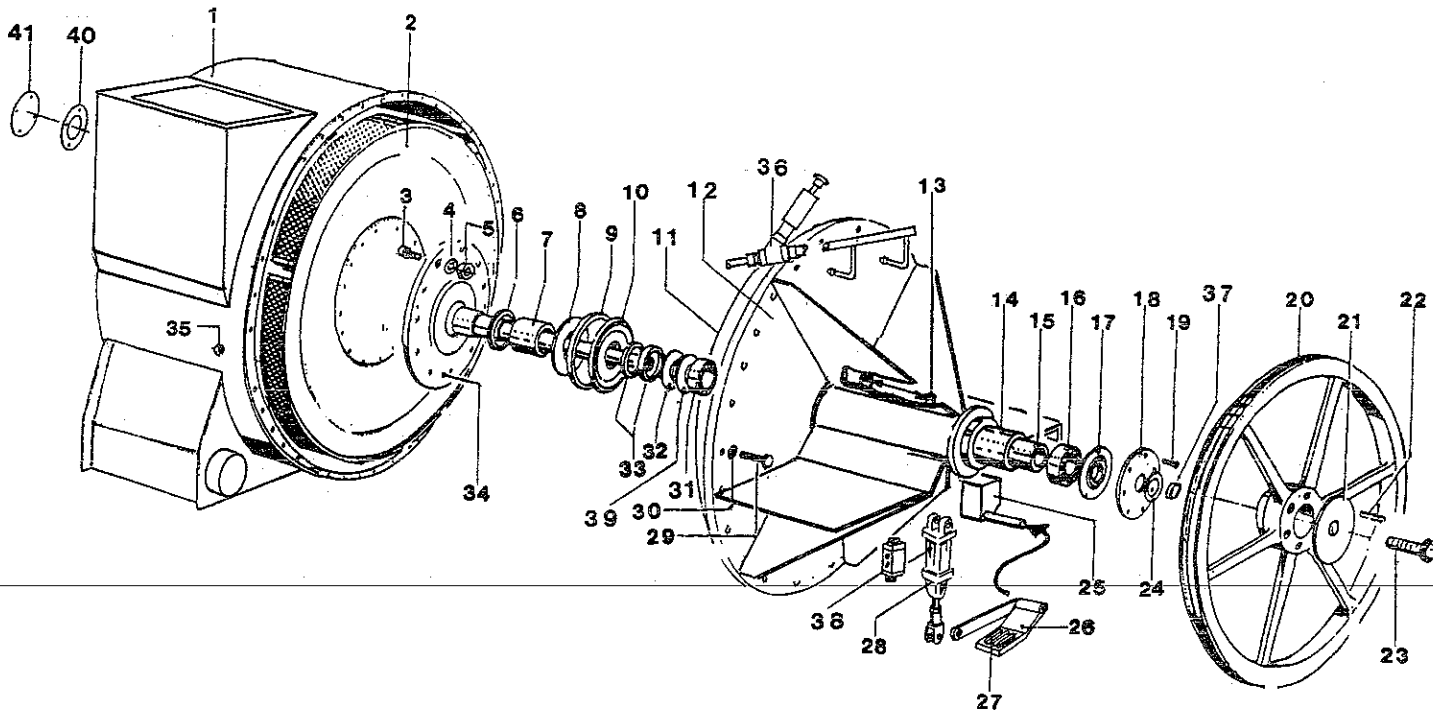

ITEM	PART NUMBER	DESIGNATION	ITEM	PART NUMBER	DESIGNATION
1	202680	TROMMELGEHÄUSE CAGE HOUSING	22	202792	SPANNSATZ CLAMP ELEMENTS
2	202553	TROMMEL CAGE	23	034253	SCHRAUBE M20 X 45 SCREW
3	202587	SCHRAUBE HALBRUND SCREW	24	100531	WELLENDICHTRING SEAL
4	038952	SICHERUNGSBLECH LOCKING PLATE	25	203881	KONSOLE CONSOLE
5	003826	MUTTER 6KT. M16 HEXAGON NUT	26	203873	HEBELBREMSE BREAK LEVER
6	202801	PROFIL-V-DICHTRING GASKET	27	053346	BREMSPLATTE PLATE
7	202928	BUCHSE-DISTANZ BUSH	28	031878	DRUCKLUFTZYLINDER PNEUMATIC RAM
8	202957	LAGER-SCHEIBE BEARING DISK	29	003191	SCHRAUBE 6KT. M12 X 50 SCREW
9	202806	ABWEISS-RING DEFLECTO RING	30	002324	FEDERRING 12 Ø SPRING WASHER
10	202807	ABWEISS-RING DEFLECTO-RING	31	010425	ZYLINDER-ROLLENLAGER ROLLER BEARING CYLINDER
11	031646	RUNDSCHNUR 8 Ø GASKET CORD	32	202805	SICHERUNGSRING CIRCLIP
12	202781	LAGER FLANSCH FLANGE BEARING	33	202794	WELLENDICHTRING GASKET SHAFT
13	134025	VERSCHRAUBUNG UNION	34	202735	FLANSCHWELLE FLANGE SHAFT
14	202955	ROHRHÜLSE TUBE BUSH	35	003821	MUTTER 6KT. M12 HEXAGON NUT
15	202943	HÜLSE-DISTANZ BUSH	36	109850	SCHRÄGSITZVENTIL 3/4" SLANTED SEAT VALVE
16	202791	RILLENKUGELLAGER GLOOVED BALL BEARING	37	025362	DISTANZRING DISTANCE RING
17	010458	DICHTRING NILOS SEAL	38	121261	3-WEGEVENTIL 3-WAY-VALVE
18	025358	ANSATZFLANSCH MIT DICHTRING FLANGE WITH SEAL	39	202788	STÜTZRING BACK-UP RING
19	003084	SCHRAUBE 6KT. M8 X 25 HEXAGON HEAD SCREW	40	206888	DICHTUNG GASKET
20	202853	RIEMENSCHLEIBE PULLEY	41	206887	DECKEL LID
21	202956	SCHEIBE DISC			

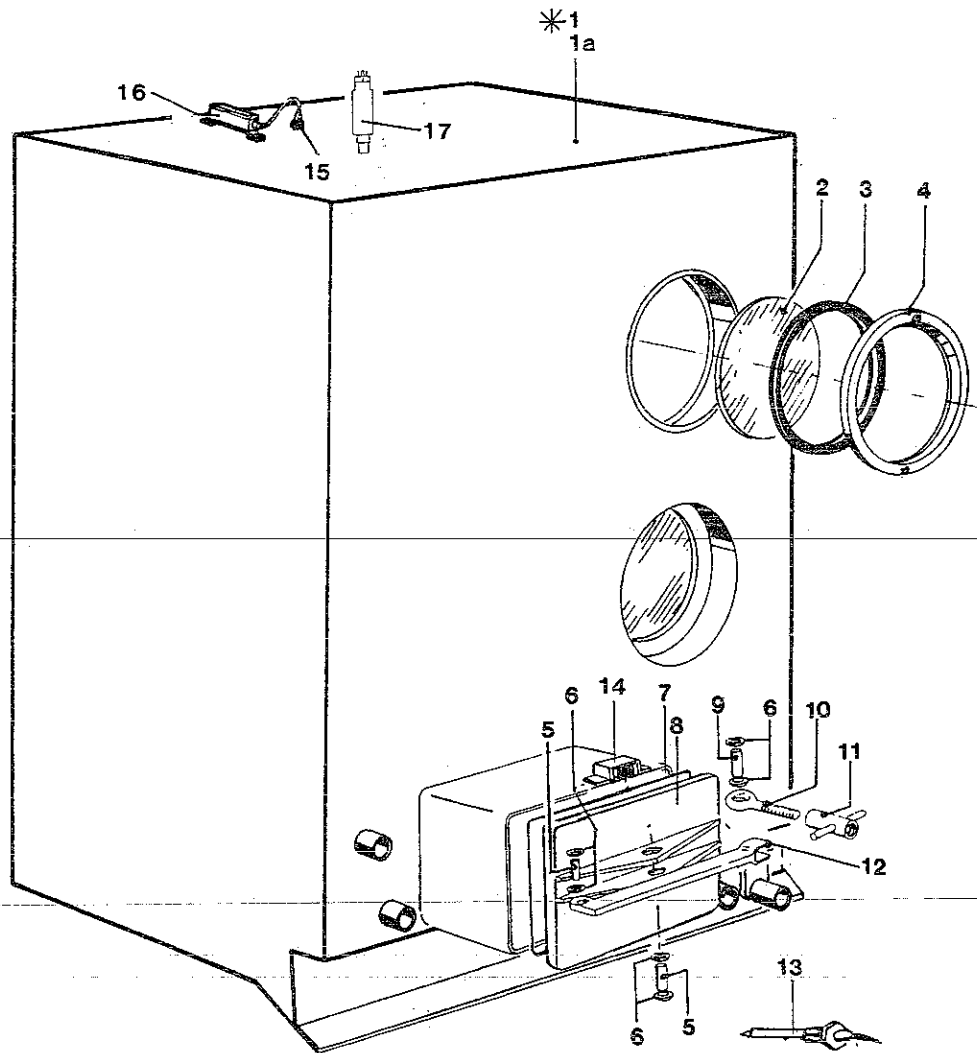

D 564

POS. ITEM	BESTELLNUMMER PART NUMBER	BENENNUNG DESIGNATION	POS. ITEM	BESTELLNUMMER PART NUMBER	BENENNUNG DESIGNATION
1	* 193874	DESTILLIERBEHÄLTER II STILL NO. II	9	051784	BOLZEN HEADLESS BOLT
1a	NEU 700560	DESTILLIERBEHÄLTER KOMPL. STILL COMPL.	10	003686	AUGENSCHRAUBE EYE SCREW
2	144137	GLASSCHEIBE GLASS PANE	11	163695	FLÜGELMUTTER WING NUT
3	195079	DICHTUNG U-PROFIL GASKET	12	156745	HEBEL LEVER
4	195078	RING RING	13	199622	TEMPERATURSENSOR THERMAL SENSOR
5	002545	BOLZEN HEADLESS BOLT	14	169930	ENDSCHALTER LIMIT SWITCH
6	002415	SCHEIBE DISC	15	125688	NIVEAUSONDE LEVEL SENSOR
7	012025	DICHTUNG GASKET	16	159058	SCHALTGERÄT CONTROL UNIT
8	197054	DECKEL MIT DICHTUNG COVER WITH GASKET	17	206412	NIVEAUSONDE KOMPL. LEVEL SENSOR COMPL.

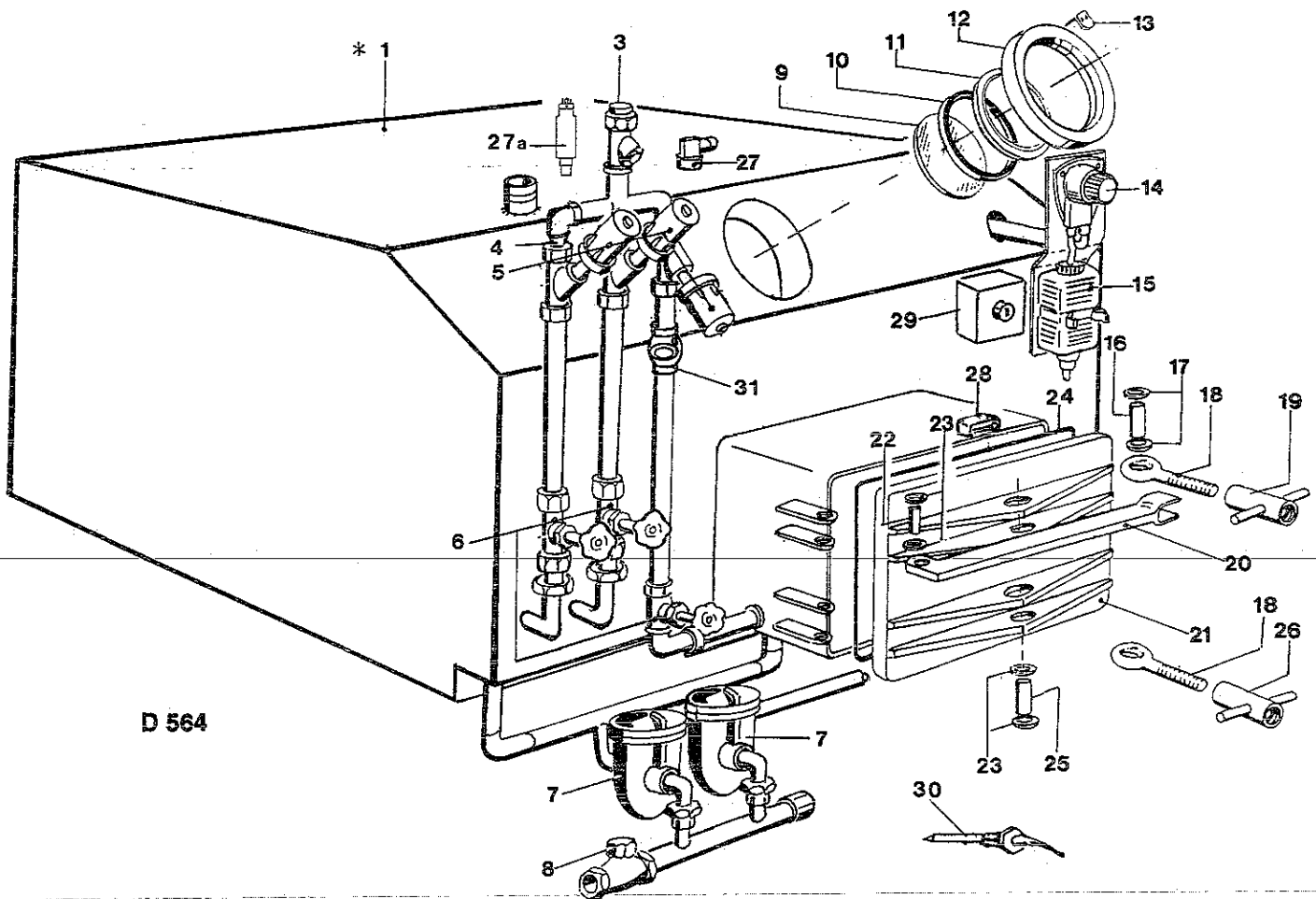

D 564

POS. ITEM	BESTELLNUMMER PART NUMBER	BENENNUNG DESIGNATION	POS. ITEM	BESTELLNUMMER PART NUMBER	BENENNUNG DESIGNATION
1	* 205927	DESTILLIERBEHÄLTER KOMPLETT STILL COMPLETE	16	002557	BOLZEN OHNE KOPF BOLT
1a	NEU * 209396	DESTILLIERBEHÄLTER KOMPLETT SCHAUGLAS SENKRECHT STILL COMPLETE SIGHT-GLASS VERTICAL	17	002447	SCHEIBE FÜR BOLZEN DISC FOR BOLT
3	031938	SCHMUTZFÄNGER 1" STRAINER	18	034233	AUGENSCHRAUBE EYE SCREW
4	020529	RED-MUFFE I/A BUSHING	19	022226	FLÜGELMUTTER WING NUT
5	031887	STEUERVENTIL F. DA 1/2" STEAM VALVE	20	021934	HEBEL LEVER
6	031892	DURCHGANGSVENTIL F. DA 1/2" THROUGH-WAY VALVE	21	037145	DECKEL LID
7	065359	KONDENSATABLEITER 1/2" STEAM TRAP	22	002556	BOLZEN OHNE KOPF HEADLESS BOLT
8	031911	RÜCKSCHLAGKLAPPE 1" CHECK FLAP	23	002446	SCHEIBE FÜR BOLZEN WASHER
9	144137	GLASSCHEIBE GLASS PANE	24	195075	DICHTUNG GASKET
10	195079	U-PROFIL-DICHTUNG GASKET	25	002555	BOLZEN OHNE KOPF HEADLESS BOLT
11	195078	RING RING	26	122685	FLÜGELMUTTER WING NUT
12	115947	SCHAUGLASRAHMEN FRAME	27	198413	NIVEAUSONDE KOMPLETT 250 MM LEVEL SENSOR COMPLETE
13	195500	HALTER HOLDER	27a	700557	NIVEAUSONDE KOMPLETT 350 MM LANG FÜR DESTILLATION SN 209396 LEVEL SENSOR FOR STILL SN 209396
	155793	HALOGENLAMPE LAMP	28	169930	ENDSCHALTER LIMIT SWITCH
	155792	LAMPENFASSUNG LAMP HOLDER	29	191312	TASTER BUTTON
14	168722	DOSIERPUMPE DOSING PUMP	30	163698	TEMPERATURSENSOR THERMASENSOR
15	166461	BEHÄLTER CONTAINER	31	125677	RÜCKSCHLAGVENTIL 1/2" CHECK VALVE

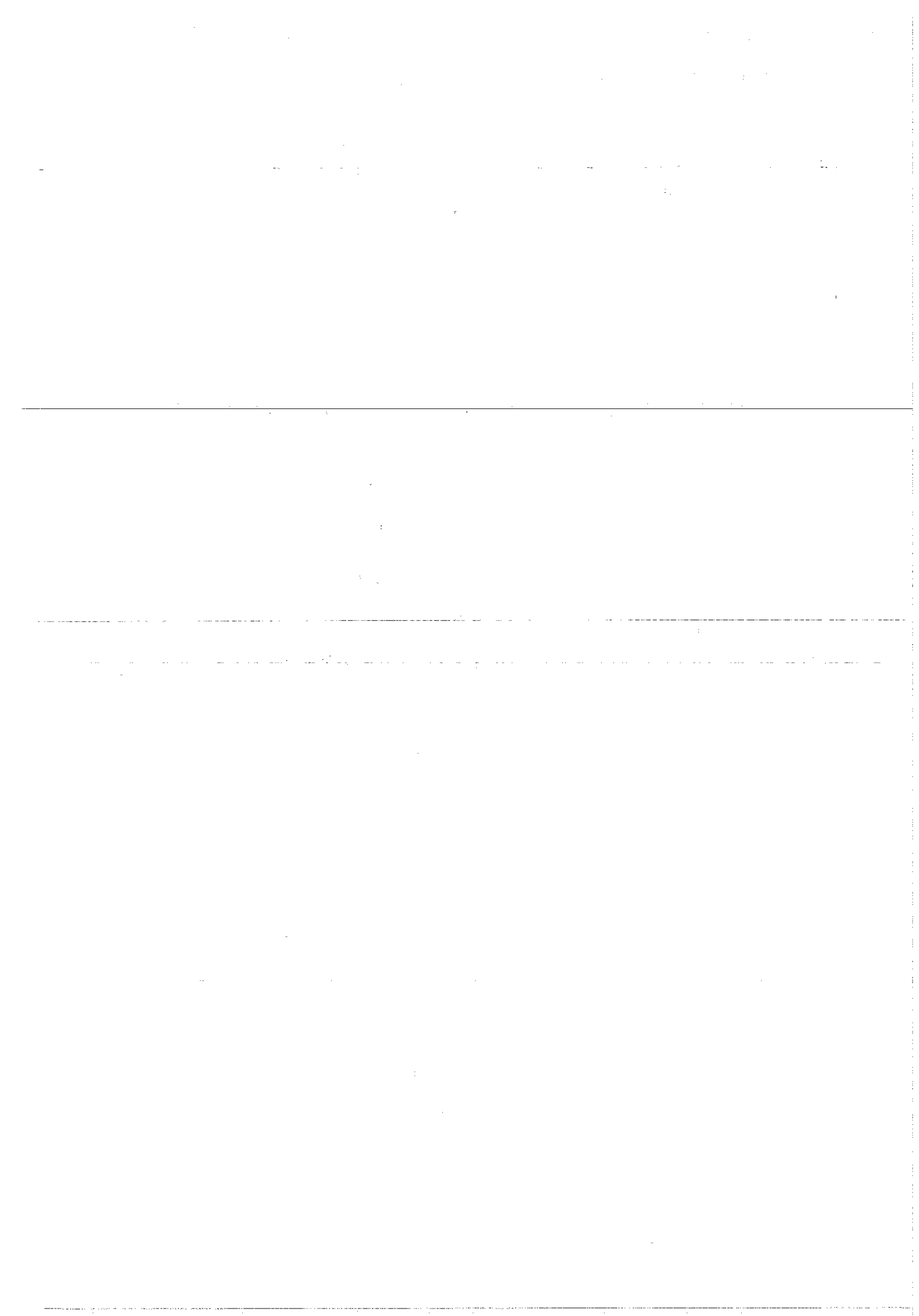

D 5.100

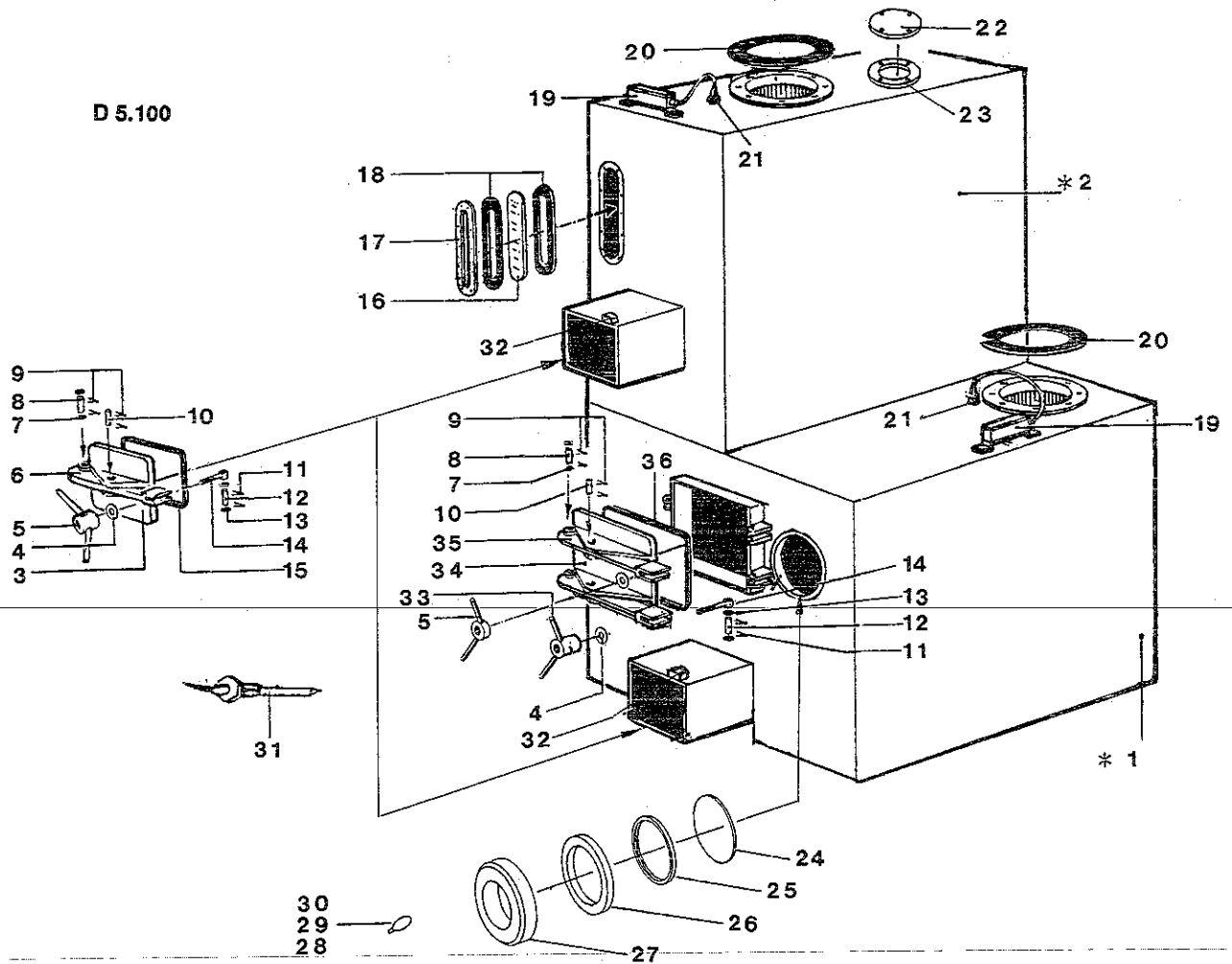

POS. ITEM	BESTELLNUMMER PART NUMBER	BENENNUNG DESIGNATION	POS. ITEM	BESTELLNUMMER PART NUMBER	BENENNUNG DESIGNATION
1	206400	DESTILLATION I KOMPLETT STILL COMPLETE	20	107758	DICHTUNG GASKET
2	207361	DESTILLATION II KOMPLETT STILL COMPLETE	21	125688	NIVEAUSONDE LEVEL SENSOR
3	106723	DECKEL COVER	22	021805	DECKEL LID
4	002419	SCHIBE 21 X 37 X 3 WASHER	23	031381	DICHTUNG 90 X 190 X 3 GASKET
5	022226	FLÜGELMUTTER M 20 WING-NUT	24	144137	GLASSCHIBE GLASS PANE
6	012024	HEBEL LEVER	25	195079	DICHTUNG U-PROFIL GASKET
7	002446	SCHEIBE 16 X 28 X 3 WASHER	26	195078	RING RING
8	002556	BOLZEN OHNE KOPF 16 X 75 X 63 HEADLESS BOLT	27	115947	SCHAUGLASRAHMEN SIGHT-GLASS FRAME
9	002353	SPLINT 4 X 25 SPLIT PIN	28	195500	HALTER HOLDER
10	002555	BOLZEN OHNE KOPF 16 X 60 X 48 HEADLESS BOLT	29	155792	LAMPENFASSUNG LAMP HOLDER
11	034232	SPLINT 5 X 30 SPLIT PIN	30	155793	HALOGENLAMPE LAMP
12	002557	BOLZEN OHNE KOPF 18 X 75 X 60 HEADLESS BOLT	31	163698	SENSOR SENSOR
13	002447	SCHEIBE 18 X 30 X 4 WASHER	32	169930	ENDSCHALTER LIMIT SWITCH
14	034233	AUGENSCHRAUBE 20 X 130 EYE-SCREW	33	122685	FLÜGELMUTTER M 20 WING-NUT
15	012025	DICHTUNG 197 X 267 X 15 X 12 GASKET	34	037145	DECKEL COVER
16	021623	SCHAUGLAS SIGHT-GLASS	35	021934	HEBEL LEVER
17	021624	FLANSCH 335 X 85 X 13 FLANGE	36	195075	DICHTUNG GASKET
18	021610	DICHTUNG 54 X 304 X 3,2 GASKET			
19	159058	STEUERGERÄT CONTROL UNIT			

POS. ITEM	BESTELLNUMMER PART NUMBER	BENENNUNG DESIGNATION	POS. ITEM	BESTELLNUMMER PART NUMBER	BENENNUNG DESIGNATION
1	195654	GRIFF HANDLE	24	030936	SCHEIBE WASHER
2	002412	SCHEIBE WASHER	25	202954	KLAPPE-LUFT KOMPLETT DAMPER-AIR COMPLETE
3	002566	BOLZEN OHNE KOPF HEADLESS BOLT	26	203660	LAGERBOCK BEARING BENCH
4	208618	HEBEL LEVER	27	202953	WELLE SHAFT
5	003667	AUGENSCHRAUBE EYE SCREW	28	194652	KÜHLREGISTER VERDAMPFER COOLING UNIT
6	203706	EINSCHUBFILTER KOMPLETT INSERTION FILTER COMPLETE	29	202914	DICHTUNG GASKET
7	203702	FILTERTUCH FILTER STRAINING CLOTH	30	202888	DECKEL KÜHLREGISTER LID
8	203703	FILTERMATTE FILTER MAT	31	148589	RUNDDICHTRING GASKET
9	195679	DICHTUNG GASKET	32	126750	FLANSCH FLANGE
10	208584	DECKEL LID	33	194653	VORWÄRMER PRE-HEATER
11	208585	DICHTUNG GASKET	34	148588	RUNDDICHTRING GASKET
12	202913	DICHTUNG LUFTSCHACHT GASKET	35	133032	FLANSCH FLANGE
13	202889	DECKEL LUFTSCHACHT LID	36	016036	GEGENMUTTER HEXAGON NUT
14	003127	SCHRAUBE 6 KT. SCREW	37	014075	DICHTSCHEIBE GASKET
15	019712	SCHEIBE WASHER	38	202874	DECKEL HEIZREGISTER LID
16	002374	SICHERUNGSBLECH LOCKING PLATE	39	202911	DICHTUNG GASKET
17	205721	PRESSLUFTZYLINDER PNEUMATIC RAM	40	202565	HEIZREGISTER DAMPF AIR HEATER STEAM
18	121261	3-WEGEVENTIL 3-WAY-VALVE	41	202926	KLAPPE VORWÄRMER KOMPLETT DAMPER PRE-HEATER COMPLETE
19	203658	HEBEL LEVER	42	202927	WELLE SHAFT
20	010484	WELLENDICHTUNG 15 X 24 X 7 SHAFT GASKET	43	194631	LAGERBOCK BEARING BENCH
21	149762	FLANSCH FLANGE	44	202867	DECKEL VORWÄRMER LID
22	144932	RUNDDICHTRING GASKET	45	202912	DICHTUNG GASKET
23	087440	BUCHSE BUSH			

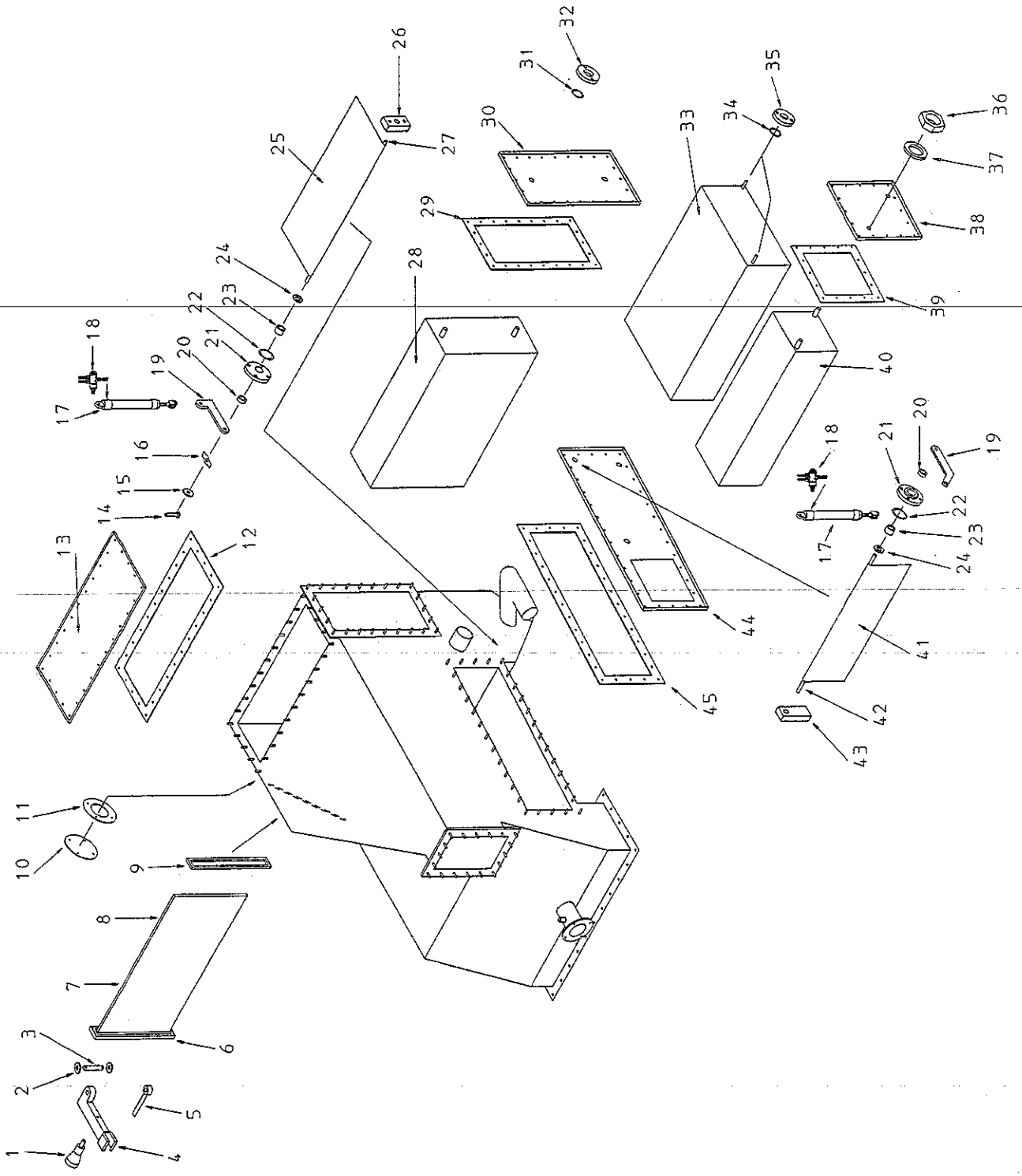

POS. ITEM	BESTELLNUMMER PART NUMBER	BENENNUNG DESIGNATION	POS. ITEM	BESTELLNUMMER PART NUMBER	BENENNUNG DESIGNATION
1	003147	SCHRAUBE 6KT. SCREW	12	208563	DICHTUNG GASKET
2	193161	SICHERUNGSSBLECH LOCKING PLATE	13	208562	DECKEL LID
3	062150	SCHEIBE DISC	14	202915	DICHTUNG GASKET
4	201978	LÜFTERRAD HL45 50 HZ FAN WHEEL	15	161338	DICHTUNG GASKET
	201883	LÜFTERRAD HL56 60 HZ FAN WHEEL	16	700281	DECKEL LID
5	202948	DICHTUNG GASKET	17	202944	LÜFTERGEHÄUSE HOUSING
6	005583	WELLENDICHRING SHAFT GASKET	18	196562	GERÄTESTECKER RECEPTACLE
7	202905	FLANSCH LATERNE FLANGE	19	166722	SCHRÄGSITZVENTIL 2 1/2" SLANTED SEAT VALVE
8	206926	LÜFTERMOTOR 230 V - 50 HZ FAN MOTOR	20	700282	FLANSCHROHR FLANGED PIPE
	201884	LÜFTERMOTOR 220 V - 60 HZ FAN MOTOR	21	030012	FLANSCHROHR FLANGED PIPE
	203687	LÜFTERMOTOR 400 V - 50 HZ FAN MOTOR	22	163546	DICHRING GASKET
9	206925	LÜFTERMOTOR KOMPLETT 230 V - 50 HZ FAN MOTOR COMPL.	23	164125	GEBLÄSE FAN
	202904	LÜFTERMOTOR KOMPLETT 400 V - 50 HZ FAN MOTOR COMPL.	24	166351	SICHERHEITSVENTIL 1/2" - 0,3 BAR SAFETY VALVE
10	202916	DICHTUNG LUFTSCHACHT GASKET			
11	109851	SCHRÄGSITZVENTIL 1 1/4" SLANTED SEAT VALVE			

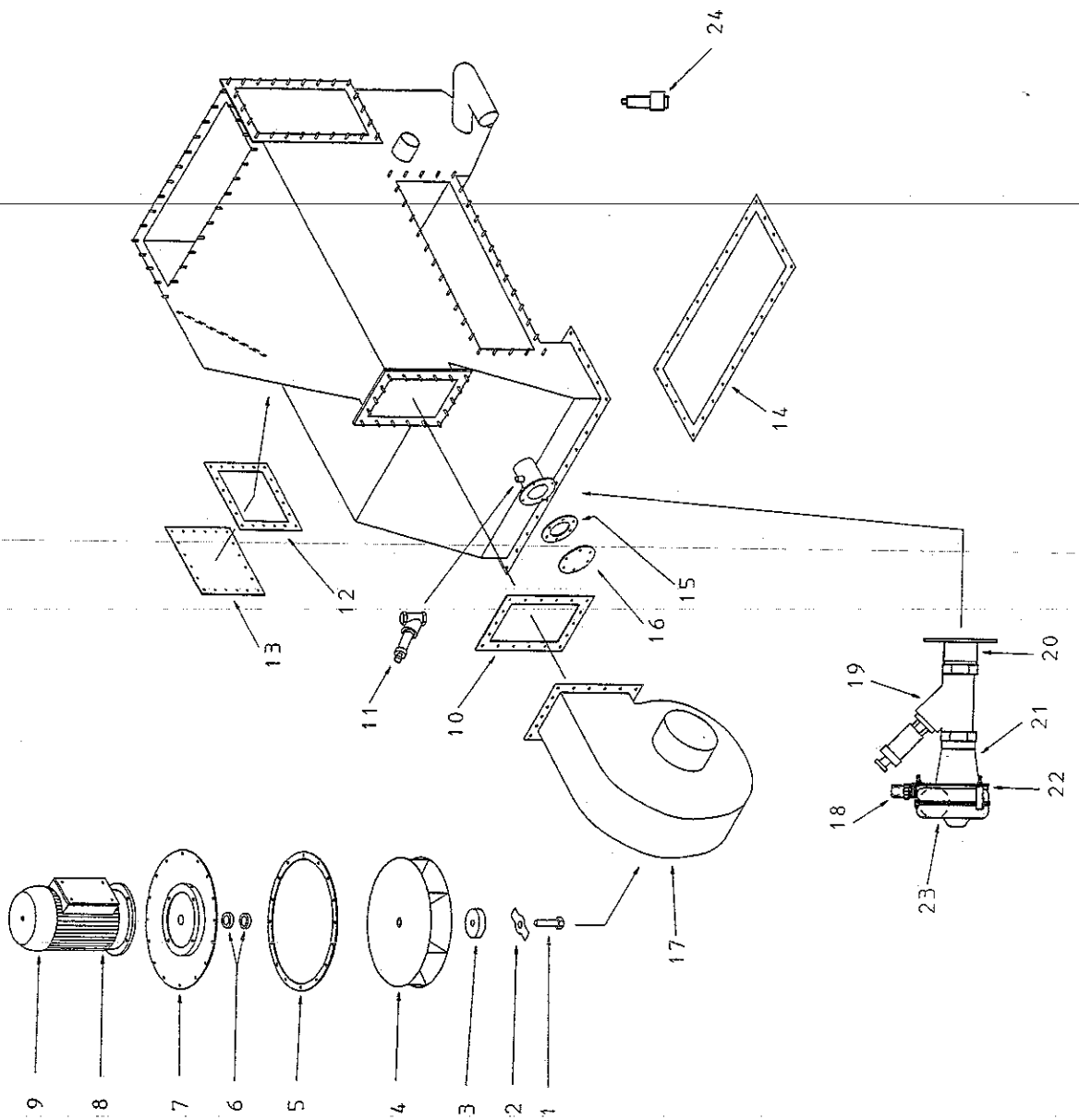

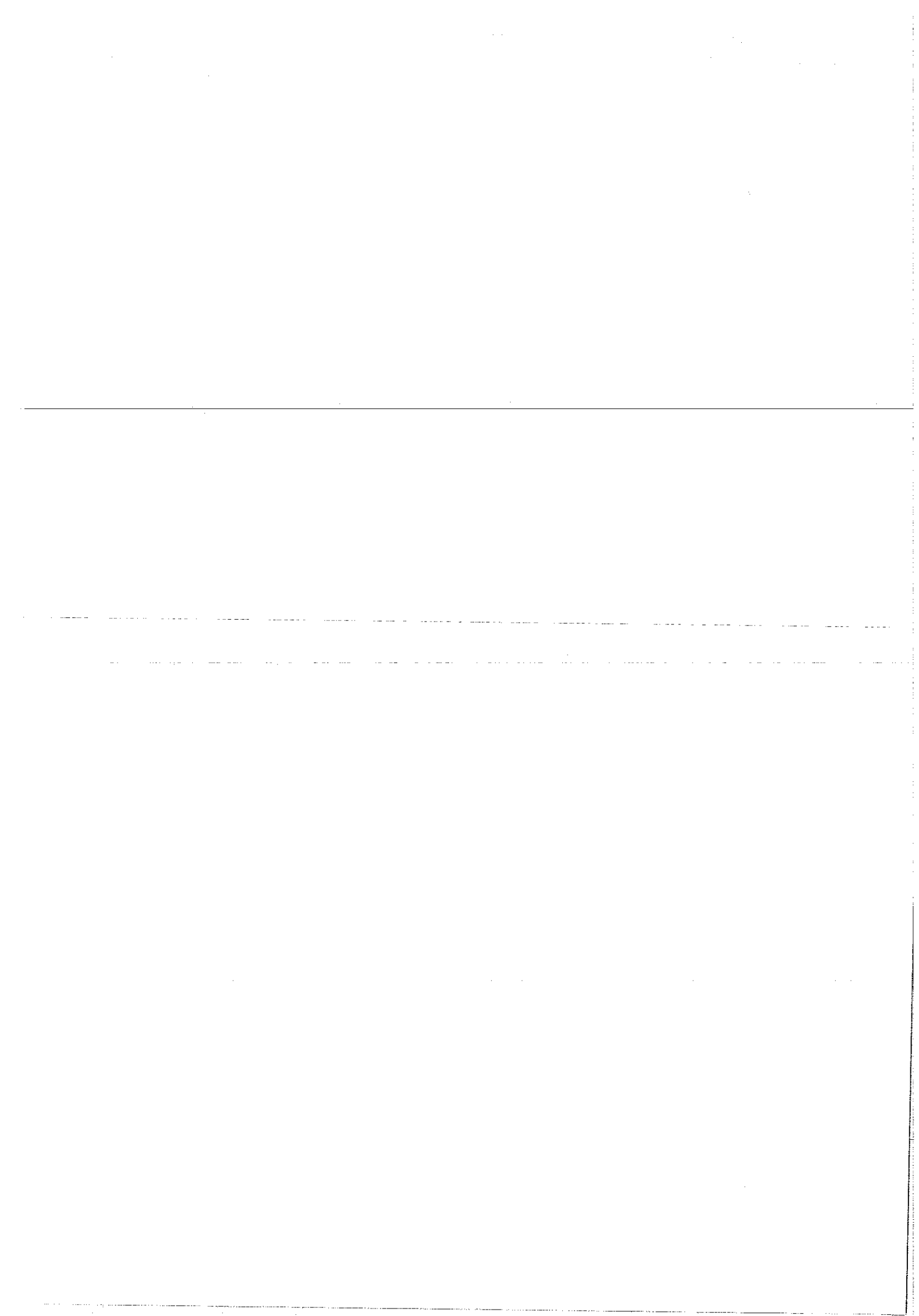

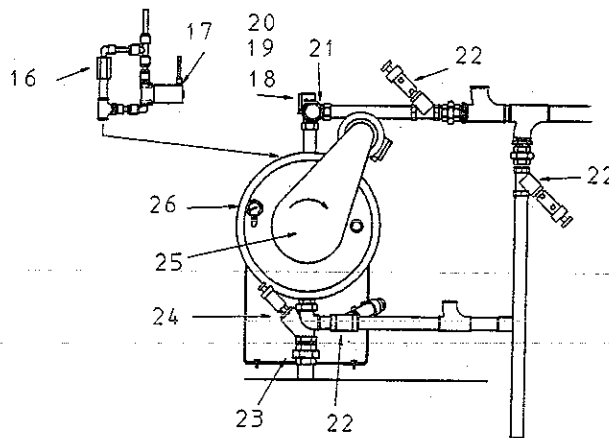
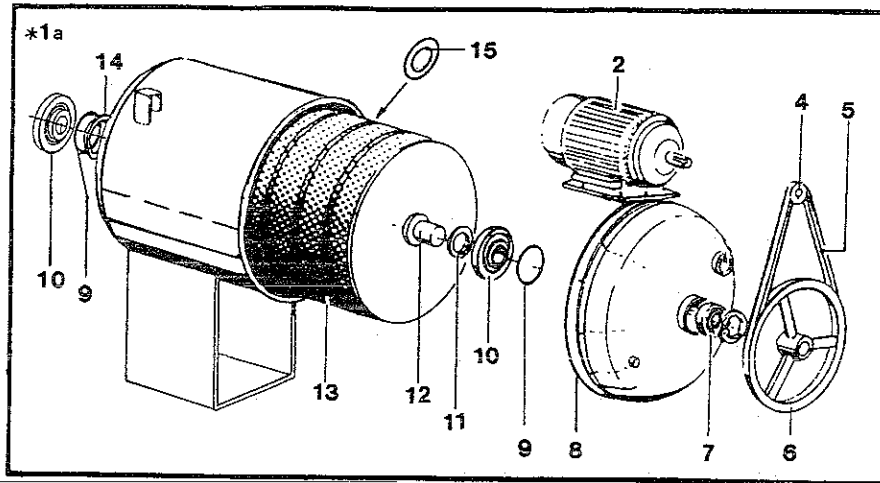

POS. ITEM	BESTELLNUMMER PART NUMBER	BENENNUNG DESIGNATION	POS. ITEM	BESTELLNUMMER PART NUMBER	BENENNUNG DESIGNATION
1	202624	ÖKO-FILTER (ANSCHWEMMFREI) 50 SCHEIBEN, 230 /400 V, 50 HZ ECO-FILTER (WITHOUT FILTER POWDER) 50 DISCS	13	191374	FILTERSCHEIBE (35 /50 STÜCK) FILTER WASHER AT-FILTERSCHEIBE EXCH.-FILTER WASHER
1a	* 195242	ÖKO-FILTER (ANSCHWEMMFREI) 35 SCHEIBEN, 230 /400 V, 50 HZ ECO-FILTER (WITHOUT FILTERPOWDER) WITH 35 DISC	14	190849	DICHTUNG FILZ GASKET
2	197357	MOTOR 230 /400 V, 50 HZ MOTOR	15	197352	FILTERSCHEIBENABDICHTUNG FILTER WASHER GASKET
4	197797	RIEMENSCHLEIBE KEIL 2 RILLIG V-BELT PULLEY	16	134723	RÜCKSCHLAGVENTIL CHECK VALVE
5	197794	KEILRIEMEN (2 STÜCK) V-BELT (2 PCE.)	17	206908	DURCHGANGSVENTIL 3/8" VALVE
6	197805	RIEMENSCHLEIBE KEIL 2 RILLIG V-BELT PULLEY	18	127597	BLENDE SHIELD
7	169984	RILLENKUGELLAGER GROOVED BEARING	19	078608	LAMPENHALTER LAMP HOLDER
8	197795	DICHTUNG GASKET	20	078609	GLÜHLAMPE LAMP
9	169986	O-RING O-RING	21	056454	DURCHGANGSSCHAUGLAS 1 1/2" TUBULAR SIGHT-GLASS
10	197796	BUCHSE BUSH	22	202494	SCHRÄGSITZVENTIL 1 1/2" SLANTED SEAT VALVE
11	169987	WELLENDICHTUNG GASKET	23	002902	VERSCHRAUBUNG 2" UNION
12	197356	WELLE FILTER ÖKO 35 SHAFT FILTER	24	169949	SCHRÄGSITZVENTIL 2" SLANTED SEAT VALVE
12a		WELLE FILTER ÖKO 50 SHAFT FILTER	25	197358	RIEMENSCHUTZ BELT GUARD
			26	168096	MANOMETER 0 - 6 BAR PRESSURE GAUGE

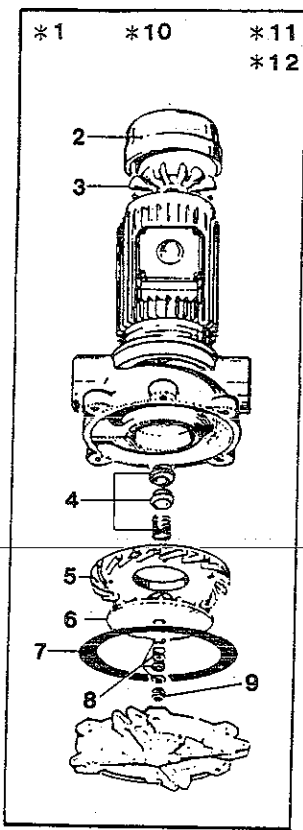

POS. ITEM	BESTELLNUMMER PART NUMBER				BENENNUNG DESIGNATION
	*1 117658	* 10 144117	*11 197843	*12 117659	PUMPE MIT MOTOR PUMP WITH MOTOR
2	093605	093605		093605	HAUBE HOAD
3	093601	093601	093600	093601	LÜFTERRAD FAN WHEEL
4	156077	156077	156077	156077	GLEITRINGDICHTUNG PUMP SEAL ASS.
5	118493	148252	078949	078949	LEITRING FÜR ET RING
6	078938	148254	078938	078939	PUMPENRAD PUMP IMPELLOR
7	052354	073039	052354	052354	GEH. DICHTUNG PUMP BASE GASKET
8	055067	055067	055067	055067	VERBINDUNG SPANNELEMENT CONNECTION CLAMP SLEEVE
9	052804	052804	052804	052804	MUTTER 6KT. HEXAGON NUT

POS. ITEM	BESTELLNUMMER PART NUMBER	BENENNUNG DESIGNATION
*1	117658	LÖSEMITTELPUMPE MIT MOTOR 230/400 V, 50 HZ PUMP WITH MOTOR
*10	144117	SCHLAMMPUMPE MIT MOTOR 190-440 V, 50 HZ, D 564 PUMP WITH MOTOR
*11	197843	SCHLAMMPUMPE MIT MOTOR 230/400 V, 50 HZ, D 5.100 PUMP WITH MOTOR
*12	117659	LÖSEMITTELPUMPE MIT MOTOR 220 /380 V, 60 HZ PUMP WITH MOTOR

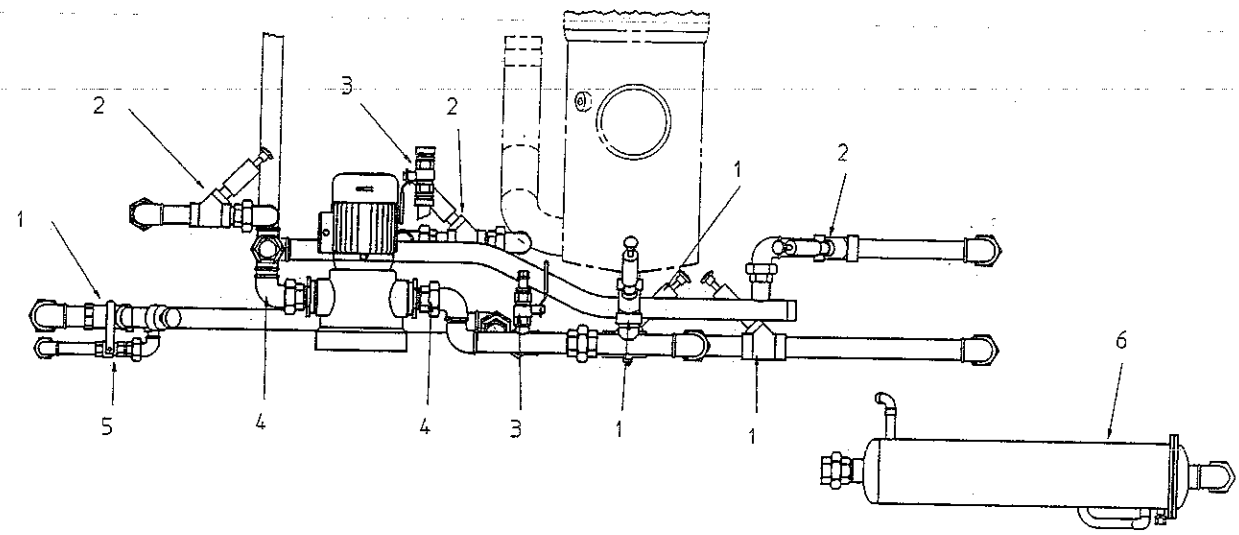

POS. ITEM	BESTELLNUMMER PART NUMBER	BENENNUNG DESIGNATION
1	202494	SCHRÄGSITZVENTIL 1 1/2" SLANTED SEAT VALVE
2	197698	SCHRÄGSITZVENTIL 1 1/4" SLANTED SEAT VALVE
3	089957	KUGELHAHN 1" BALL-COCK
4	002801	WINKELVERSCHRAUBUNG ELBOW UNION
5	116328	KUGELHAHN 3/4" BALL-COCK VALVE
6	206853	FLOTTENKÜHLER SOLVENT COOLER



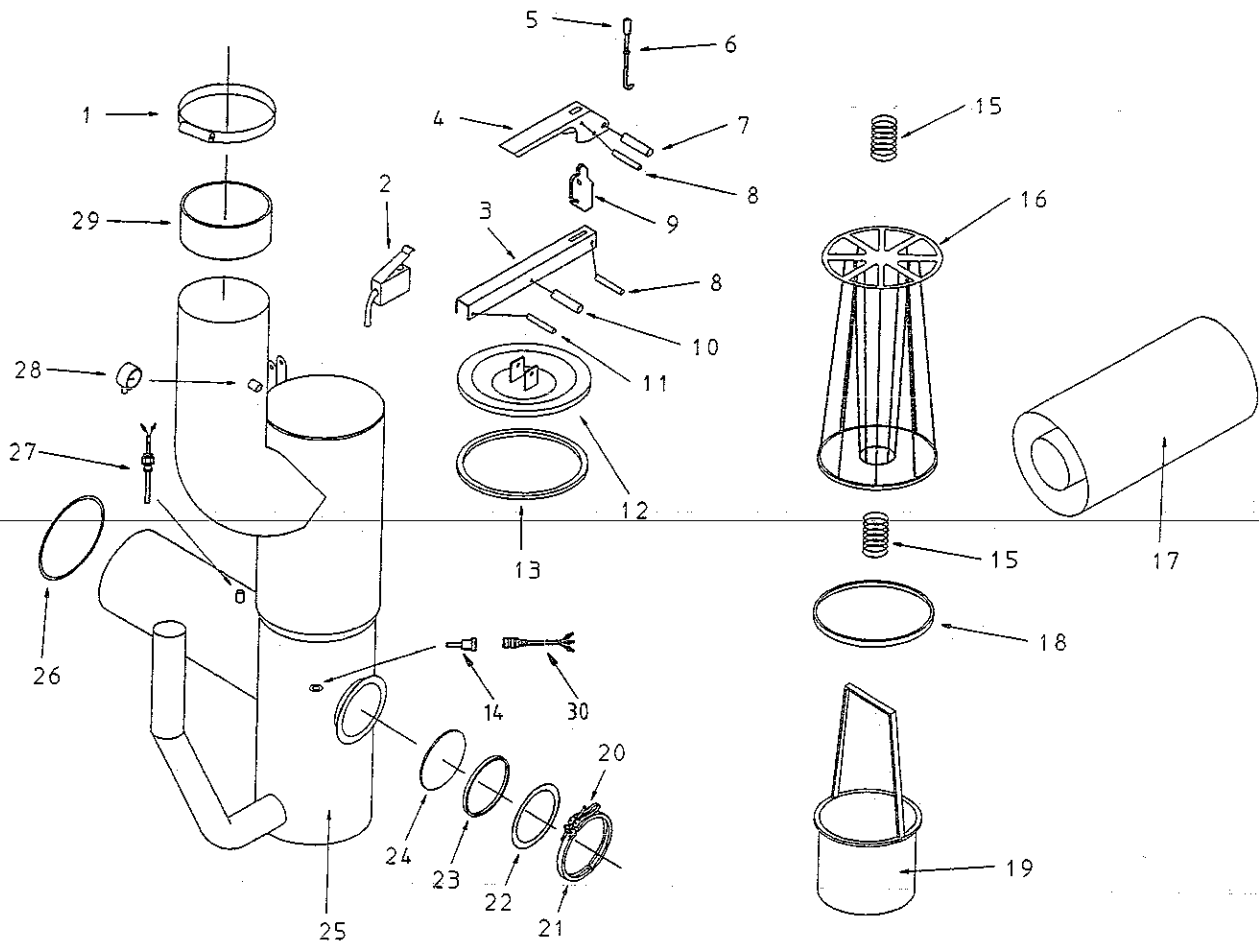

POS. ITEM	BESTELLNUMMER PART NUMBER	BENENNUNG DESIGNATION	POS. ITEM	BESTELLNUMMER PART NUMBER	BENENNUNG DESIGNATION
1	169615	SCHLAUSCHELLE CLAMP HOSE	16	207281	FLUSENFILTER-KORB LINT FILTER BASKET
2	169930	ENDSCHALTER LIMIT SWITCH	17	207284	FLUSENFILTER-TUCH LINT FILTER STRAINING CLOTH
3	194957	SPANNHEBEL LEVER	18	194964	DICHRING-FILZ GASKET
4	160729	VERSCHLUSSGRIFF HANDLE	19	198079	SIEBKORB STRAINER
5	164812	ZYLINDERKNOPF KNOB	20	196505	KLAPPSTECKER FLAP PLUG
6	164386	VERSCHLUSSHAKEN HOOK	21	196290	SPANNSCHELLE CLAMP
7	160776	WELLE HEADLESS BOLT	22	134389	SCHAUGLASRING RING FOR SIGHT-GLASS
8	160731	WELLE HEADLESS BOLT	23	149253	DICHRING U-PROFIL GASKET RING
9	160728	VERSCHLUSSHAKEN HOOK	24	149288	GLASSCHEIBE GLASS
10	160733	WELLE HEADLESS BOLT	25	203675	NADELFÄNGER KOMPL. BUTTON TRAP COMPL.
11	160732	WELLE HEADLESS BOLT	26	195289	O-RING 250 X 7 O-RING
12	208747	DECKEL NADELFÄNGER LID	27	161162	TEMPERATURSENSOR THERMAL SENSOR
13	195340	DICHTUNG GASKET	28	031987	VAKUUMMANOMETER VAC. PRESS. GAUGE
14	701603	FÜLLSTANDSSENSOR LEVEL SENSOR	29	194811	LUFTSCHLAUCH AIR HOSE
15	100375	DRUCKFEDER SPRING	30	701604	KUPPLUNG MIT KABEL COUPLING WITH CABLE

POS. ITEM	BESTELLNR. PART NO.	BENENNUNG DESIGNATION	POS. ITEM	BESTELLNR. PART NO.	BENENNUNG DESIGNATION	POS. ITEM	BESTELLNR. PART NO.	BENENNUNG DESIGNATION
1	* 700070	NADELFÄNGER KOMPL. BUTTON TRAP COMPL.	22	144298	LAGERBUCHSE 22 X 28 X 25 BEARING BUSH	45	002415	SCHEIBE 13 X 24 X 2,5 WASHER
2	* 700641	NADELFÄNGER- EINSATZ KOMPL. BUTTON TRAP STRAINER COMPL.	23	134136	FLANSCHBUCHSE FLANGED BUSH	46	002543	BOLZEN OHNE KOPF 12 X 45 HEADLESS BOLT
3	139361	PASSFEDER 5 X 5 X 18 FITTING-KEY	24	134140	SCHEIBE WASHER	47	209647	BOLZEN OHNE KOPF 12 X 192 HEADLESS BOLT
4	053172	GEWINDESTIFT 5 X 15 THREADED PIN	25	134132	WELLE SHAFT	48	003681	AUGENSCHRAUBE M 12 X 80 EYE-SCREW
5	125630	KETTENRAD CHAIN WHEEL	26	134138	LAUFROLLE PULLEY	49	169930	ENDSCHALTER LIMIT SWITCH
6	139028	NABE HUB	27	134147	BÜRSTE BRUSH	50	700825	ABSTREIFER SCARPER
7	007358	SCHEIBE 16,2 X 25 X 2 WASHER	28	129239	KETTENGLIED CHAIN LINK	51	126873	DRUCKFEDER 2 X 18 X 13 PRESSURE SPRING
8	001370	RILLENKUGELLAGER 7 X 35 X 10 GROOVED BALL BEARING	29	125680	KETTENGLIED CHAIN LINK	52	701938	SCHWIMMER MAGNET FLOAT
9	139027	BUCHSE BUSH	30	700009	KETTE CHAIN	53	700163	FLUSENFILTER- TUCH LINT FILTER STRAINING CLOTH
10	001183	SICHERUNGSRING 35 X 1,5 CIRCLIP	31	700090	KETTENGLIED CHAIN LINK	54	139407	SCHRÄGSITZ- VENTIL 1" SLANTED SEAT VALVE
11	001872	RILLENKUGELLAGER 17 X 35 -16003 GROOVED BALL BEARING	32	067957	KETTE CHAIN	55	031887	STEUERVENTIL FÜR DAMPF 1/2" CONTROL VALVE FOR STEAM
12	125681	WELLENDICHTRING 20 X 35 X 7 SHAFT GASKET	33	197881	GETRIEBEMOTOR 230/400 V, 50 HZ GEAR MOTOR	56	031940	FILTER SCHMUTZFÄNGER STRAINER
13	134162	SCHEIBE 21 X 34 X 1 WASHER	34	125629	KETTENRAD CHAIN WHEEL	57	031892	DURCHGANGS- VENTIL FÜR DAMPF 1/2" TROUGH-WAY VALVE
14	125608	DICHTUNG GASKET	35	002508	PASSFEDER 6 X 6 X 25 FITTING KEY	58	209644	FLUSENKORB LINT BASKET
15	139026	WELLE SHAFT	36	209402	BEHÄLTER NADELFÄNGER BUTTON TRAP TANK	59	700802	SIEBKORB STRAINER
16	134133	FLANSCHWELLE FLANGE-SHAFT	37	194811	LUFTSCHLAUCH AIR HOSE	60	031913	RÜCKSCHLAG- KLAPPE 1/2" CHECK FLAP
17	134135	MITNEHMER CARRIER	38	169615	SCHLAUCHSCHELLE CLAMP HOSE	61	109360	KONDENSAT- ABLEITER 1/2" STEAM TRAP
18	144297	DRUCKFEDER 2,2 X 26 X 30 PRESSURE SPRING	39	195674	DICHTUNG PROFIL GASKET	62	194705	DICHTUNG GASKET
19	134137	KETTENRAD CHAIN WHEEL	40	195670	DECKEL NADELFÄNGER COVER	63	195289	DICHTUNG GASKET
20	148576	ZYLINDERSTIFT 6 X 45 CYLINDRICAL PIN	41	209575	HEBEL NADELFÄNGER LEVER	64	701938	SCHALTER NIVEAU LEVEL SWITCH
21	134139	SCHEIBE WASHER	42	700086	FLÜGELMUTTER WING NUT			
			43	143084	AUGENSCHRAUBE M12 X 120 EYE SCREW			
			44	002347	SPLINT 3,2 X 25 SPLIT PIN			

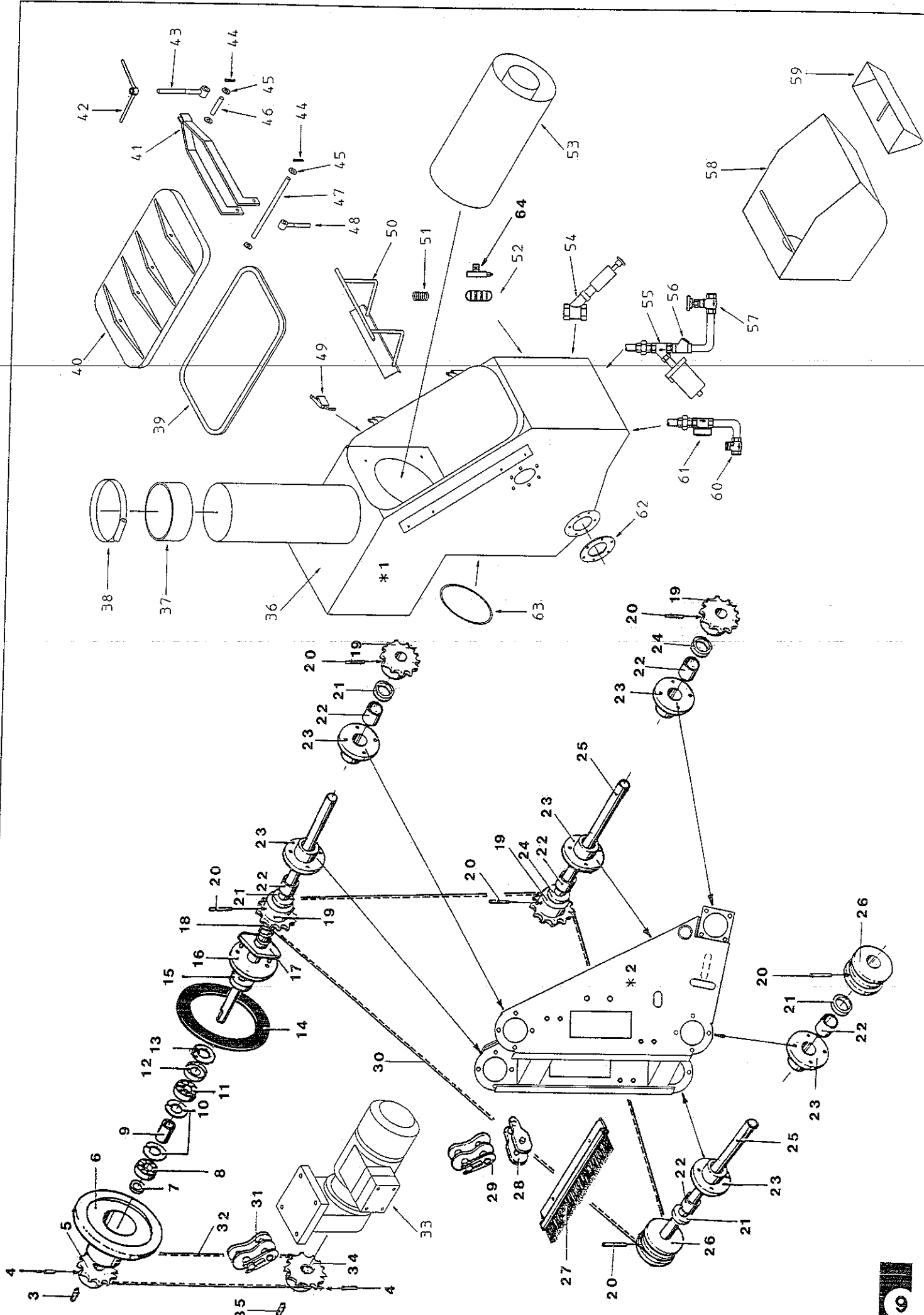

D 5.100

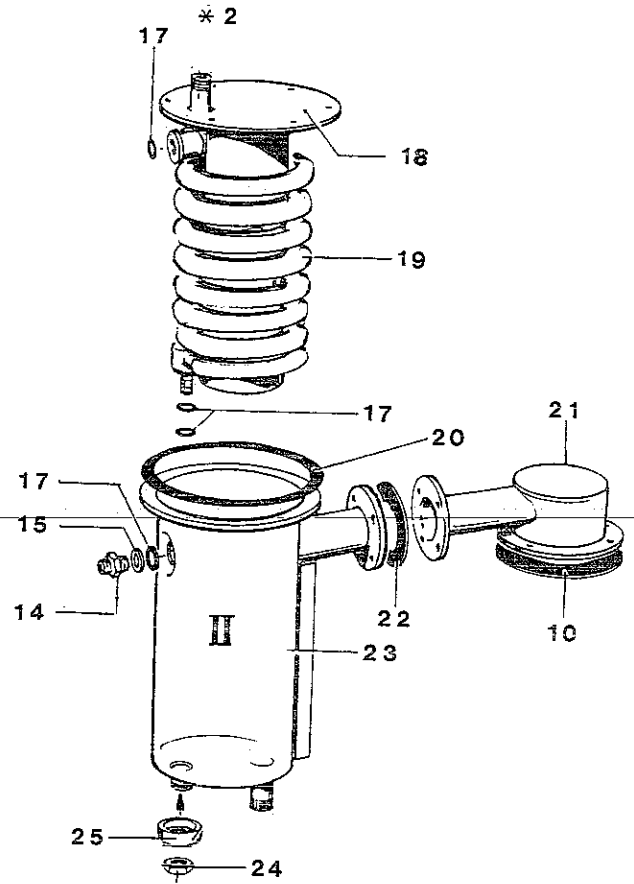
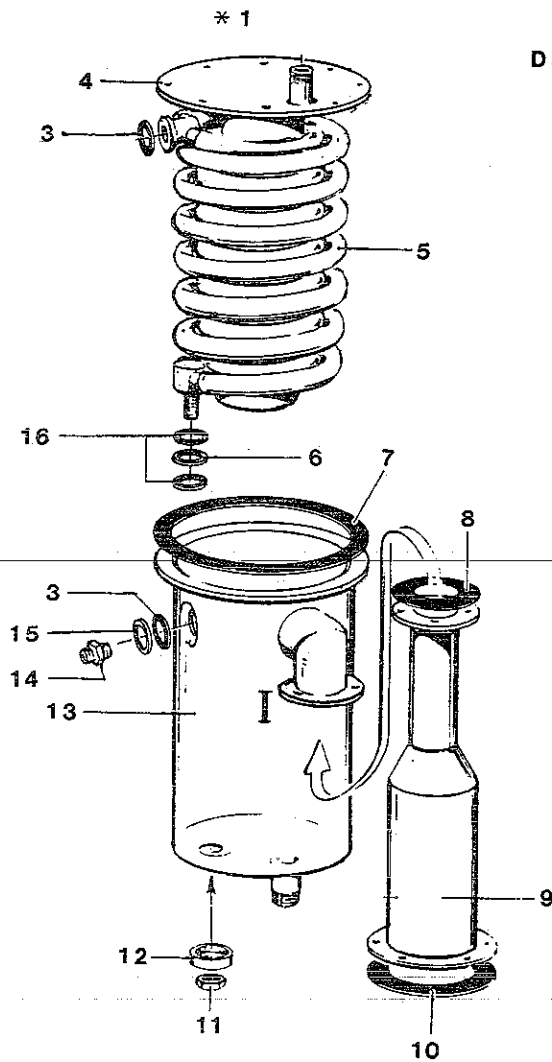

POS. ITEM	BESTELLNUMMER PART NUMBER	BENENNUNG DESIGNATION
1	* 105612	KONDENSATOR I KOMPL. CONDENSER I COMPL.
2	* 105842	KONDENSATOR II KOMPL. CONDENSER II COMPL.
3	072623	DICHTSCHEIBE 27 X 38 X 2 GASKET
4	105609	KONDENSATORDECKEL CONDENSER COVER
5	022287	KÜHLSCHLANGE CONDENSER COIL
6	103485	SCHEIBE WASHER
7	080801	DICHTUNG GASKET
8	026364	FLANSCHDICHTUNG 90 X 160 X 3 FLANGED GASKET
9	206399	STEIGROHR ASCENDING-PIPE
10	107758	DICHTUNG GASKET
11	018026	SECHSKANTMUTTER 3/4" HEXAGON NUT
12	015526	SCHEIBE 28 X 42 X 8 WASHER
13	105608	KONDENSATOR-KESSEL CONDENSER TANK

POS. ITEM	BESTELLNUMMER PART NUMBER	BENENNUNG DESIGNATION
14	015529	DOPPELNIPPEL 3/4" DOUBLE NIPPLE
15	015602	SCHEIBE WASHER
16	026365	DICHTSCHEIBE 32 X 45 X 3 GASKET
17	057037	DICHTSCHEIBE 27 X 40 X 4 GASKET
18	105839	KONDENSATORDECKEL CONDENSER COVER
19	105840	KÜHLSCHLANGE CONDENSER COIL
20	080811	DICHTUNG GASKET
21	106382	DOM DOME
22	029978	FLANSCHDICHTUNG 65 X 130 X 3 FLANGED GASKET
23	105841	KONDENSATOR-KESSEL CONDENSER TANK
24	016036	SECHSKANTMUTTER 1/2" HEXAGON NUT
25	015527	SCHEIBE 23 X 42 X 8 WASHER

*1

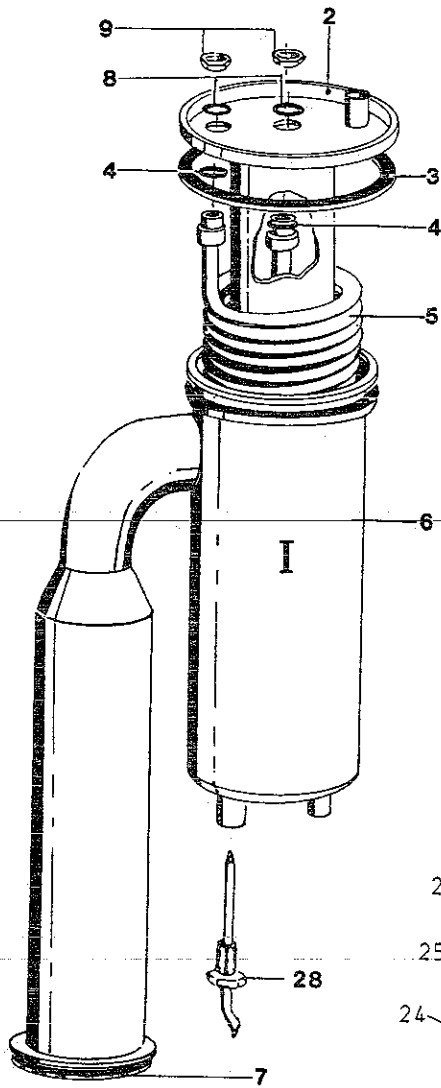

*10

D 564

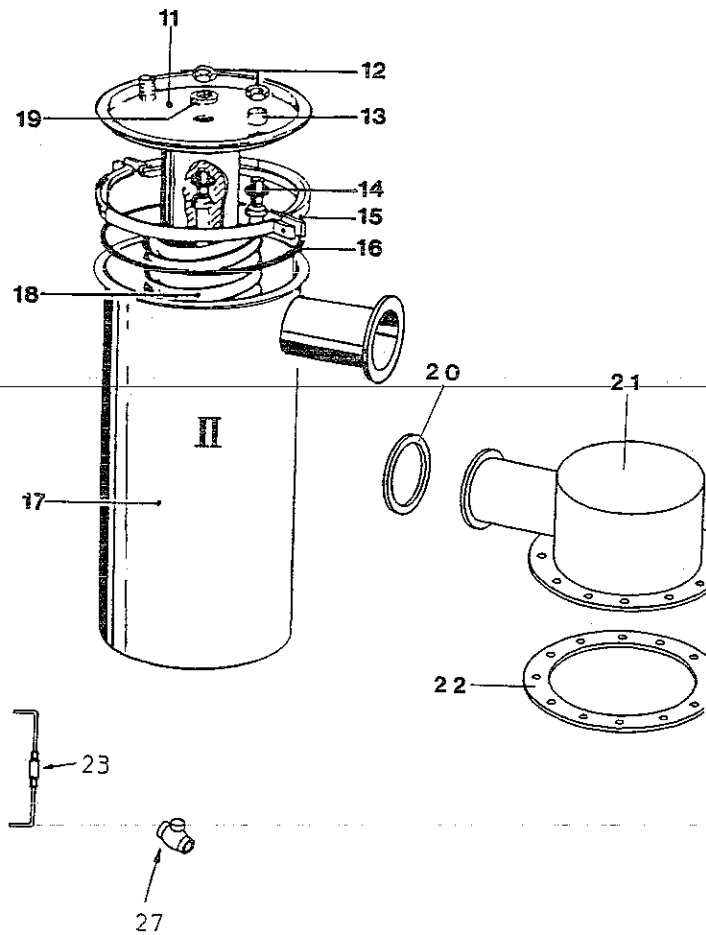

POS. ITEM	BESTELLNUMMER PART NUMBER	BENENNUNG DESIGNATION
1	* 194870	KONDENSATOR I KOMPLETT CONDENSER I COMPLETE
2	194872	KONDENSATOREINSATZ CONDENSER INSERT
3	194875	FLANSCHDICHTUNG GASKET
4	022304	DICHTUNG GASKET
5	194866	KONDENSATORSPIRALE CONDENSER COIL
6	194867	KONDENSATORKESSL CONDENSER TANK
7	194597	O-RING O-RING
8	076226	SCHEIBE WASHER
9	018026	GEGENMUTTER NUT
10	* 030032	KONDENSATOR II KOMPLETT CONDENSER II COMPLETE
11	143843	KONDENSATOREINSATZ CONDENSER INSERT
12	016036	GEGENMUTTER HEXAGON NUT
13	148849	BUCHSE BUSH
14	149281	DICHRING GASKET RING

POS. ITEM	BESTELLNUMMER PART NUMBER	BENENNUNG DESIGNATION
15	156040	SPANNSCHELLE CLAMP
16	151051	O-RING O-RING
17	030031	KONDENSATORKESSL CONDENSER TANK
18	149382	KONDENSATORSPIRALE CONDENSER COIL
19	015527	SCHEIBE WASHER
20	133965	DICHTUNG GASKET
21	190262	DOM DOME
22	194597	DICHTUNG GASKET
23	116976	DURCHGANGSVENIL 1/8" THROUGH-WAY-VALVE
24	031939	SCHMUTZFÄNGER 3/4" STRAINER
25	087897	DRUCKWÄCHTER PRESSURE CONTROL SWITCH
26	091614	KÜHLWASSERREGLER 3/4" COOLING WATER REGULATOR
27	134723	RÜCKSCHLAGVENTIL CHECK VALVE
28	161162	TEMPERATURSENSOR THERMALSENSOR

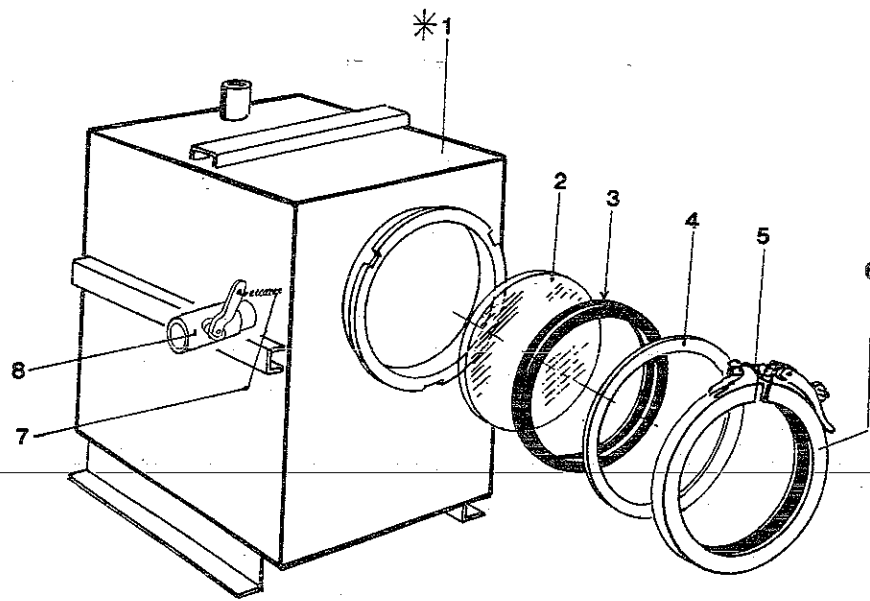

POS. ITEM	BESTELLNUMMER PART NUMBER	BENENNUNG DESIGNATION
1	* 700591	WASSERABSCHIEDER II WATER SEPARATOR
2	149288	GLASSCHEIBE GLASS
3	149253	DICHTRING PROFIL U GASKET RING
4	134389	SCHAUGLASRING RING FOR SIGHT-GLASS
5	196505	KLAPPSTECKER FLAP PLUG
6	196290	SPANNSCHELLE CLAMP
7	047510	FEDER SPRING
8	113979	KUGELHAHN 1/2" BALL COCK VALVE

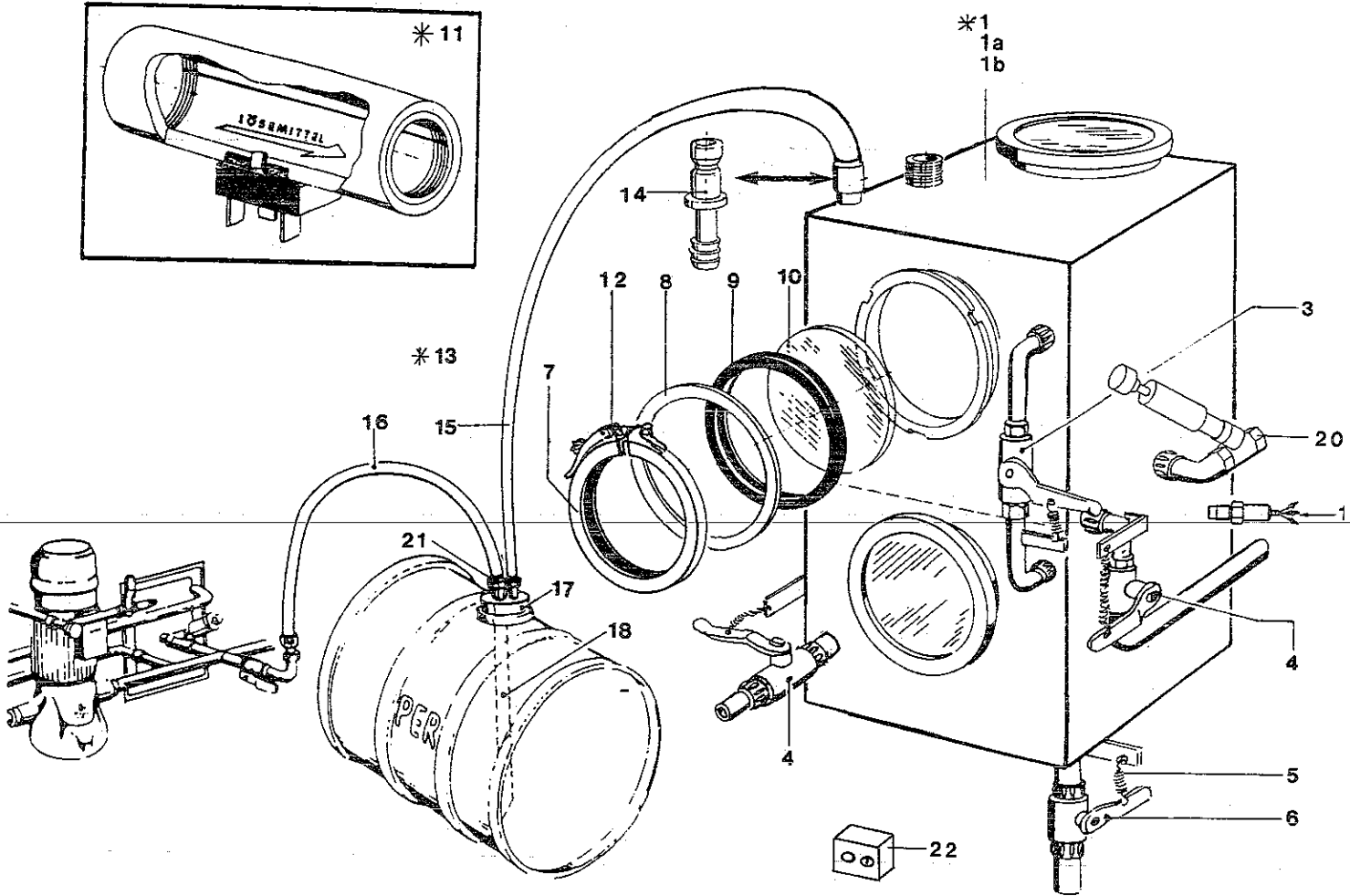

POS. ITEM	BESTELLNUMMER PART NUMBER	BENENNUNG DESIGNATION
1	* 209321	WASSERABSCHIEDER I WATER SEPARATOR
1a	205713	WASSERABSCHIEDER KOMPL FÜR DESTILLATION SN 206400 WATER SEPARATOR COMPL FOR STILL SN 206400
1b	700268	WASSERABSCHIEDER I "o"-MASCHINE WATER SEPARATOR "o"-MACHINE
3	113979	KUGELHAHN 1/2" BALL-COCK VALVE
4	116328	KUGELHAHN 3/4" BALL-COCK VALVE
5	047510	ZUGFEDER TENSION SPRING
6	089957	KUGELHAHN 1" BALL-COCK VALVE
7	196290	SPANNSCHELLE CLAMP
8	134389	SCHAUGLASSRING RING FOR SIGHT-GLASS
9	149253	DICHTRING PROFIL U GASKET RING
10	149288	GLASSCHEIBE GLASS
11	* 191778	TROCKENZEITKONTROLLGERÄT DRYSTAT UNION

POS. ITEM	BESTELLNUMMER PART NUMBER	BENENNUNG DESIGNATION
12	196505	KLAPPSTECKER FLAP PLUG
13	* 195060	LÖSEMITTELAUFFÜLLUNG KOMPLETT SOLVENT FILLING COMPLETE
14	166063	STECKNIPPEL PLUG-IN NIPPLE
15	129990	SCHLAUCH PVC 19 X 4 HOSE
16	206805	SCHLAUCH PERBUNAN HOSE
17	166131	STOPFEN PLUG
18	155991	TAUCHROHR IMMERSION PIPE
19	700067	FÜLLSTANDSSENSOR LEVEL SENSOR
20	109850	SCHRÄGSITZVENTIL 3/4" SLANTED SEAT VALVE
21	161252	SCHLAUCHSCHELLE HOSE CLAMP
22	193001	TASTER-DREHSCHALTER BUTTON-TURN SWITCH

POS. ITEM	BESTELLNUMMER PART NUMBER	BENENNUNG DESIGNATION	POS. ITEM	BESTELLNUMMER PART NUMBER	BENENNUNG DESIGNATION
1	161338	FLANSCHDICHTUNG GASKET	14	195826	KOHLEMATTE KOMPL CARBON MAT COMPL
2	166250	SCHLAUCH 90 X 100 HOSE	15	016036	GEGENMUTTER HEXAGON-NUT
3	119724	SCHLAUCHSCHELLE HOSE CLAMP	16	014075	DICHTSCHEIBE GASKET
4	205638	SCHRÄGSITZVENTIL 3" SLANTED SEAT VALVE	17	031887	DAMPFVENTIL 1/2" STEAM VALVE
5	074985	O-RING O-RING	18	031940	FILTER SCHMUTZFÄNGER 1/2" STRAINER
6	109851	SCHRÄGSITZVENTIL 1 1/4" SLANTED SEAT VALVE	19	202588	HEIZREGISTER DAMPF STEAM HEATER
7	194705	FLANSCHDICHTUNG GASKET	20	203729	DICHTUNG HEIZREGISTER GASKET
8	191626	VENTILATOR HOCHDRUCK 220 /380 V, 50 HZ FAN	21	163698	TEMPERATURSENSOR THERMAL SENSOR
9	195627	KEILRIEMEN 50 HZ V-BELT	22	703252	AKTIVKOHLE CARBON
10	195619	MOTOR 220 /380 V, 50 HZ MOTOR	23	166244	SIEB-AUFLAGE SUPPORTING SURFACE
		MOTOR 220 V, 60 HZ MOTOR	24	700569	DICHTUNG GASKET
11	203864	DECKEL LID	25	700584	DECKEL-AKTIVKOHLE LID-CARBON
12	203731	DICHTUNG GASKET	26	031913	RÜCKSCHLAGKLAPPE 1/2" CHECK FLAP
13	166778	KOHLEMATTE CARBON MAT	27	109360	KONDENSATABLEITER 1/2" STEAM TRAP

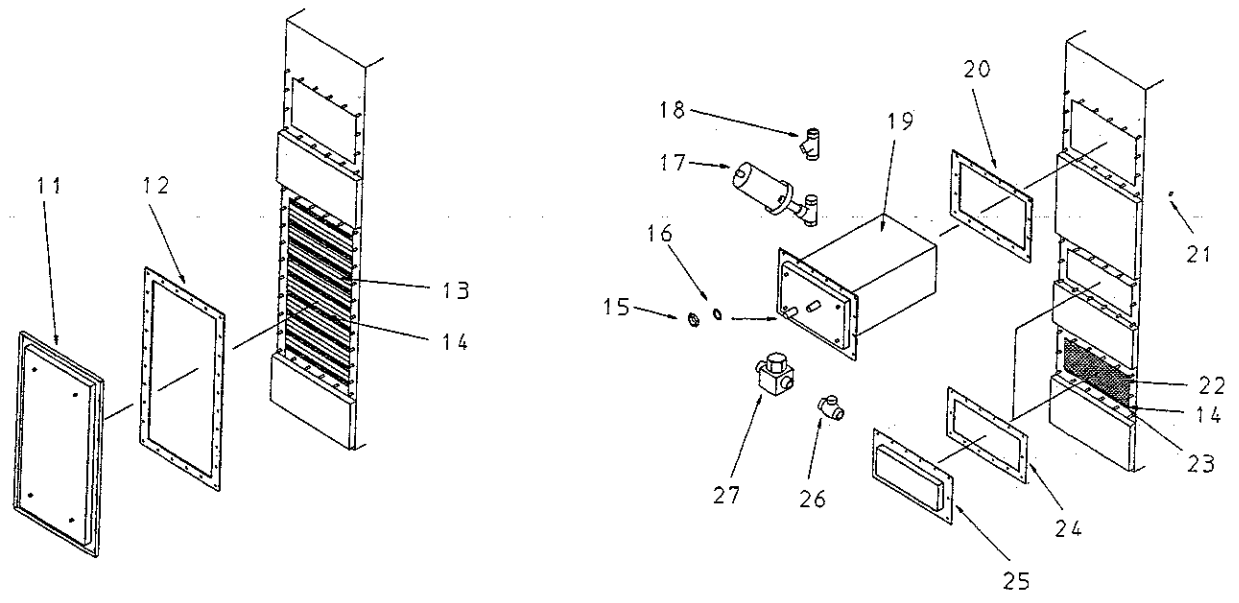
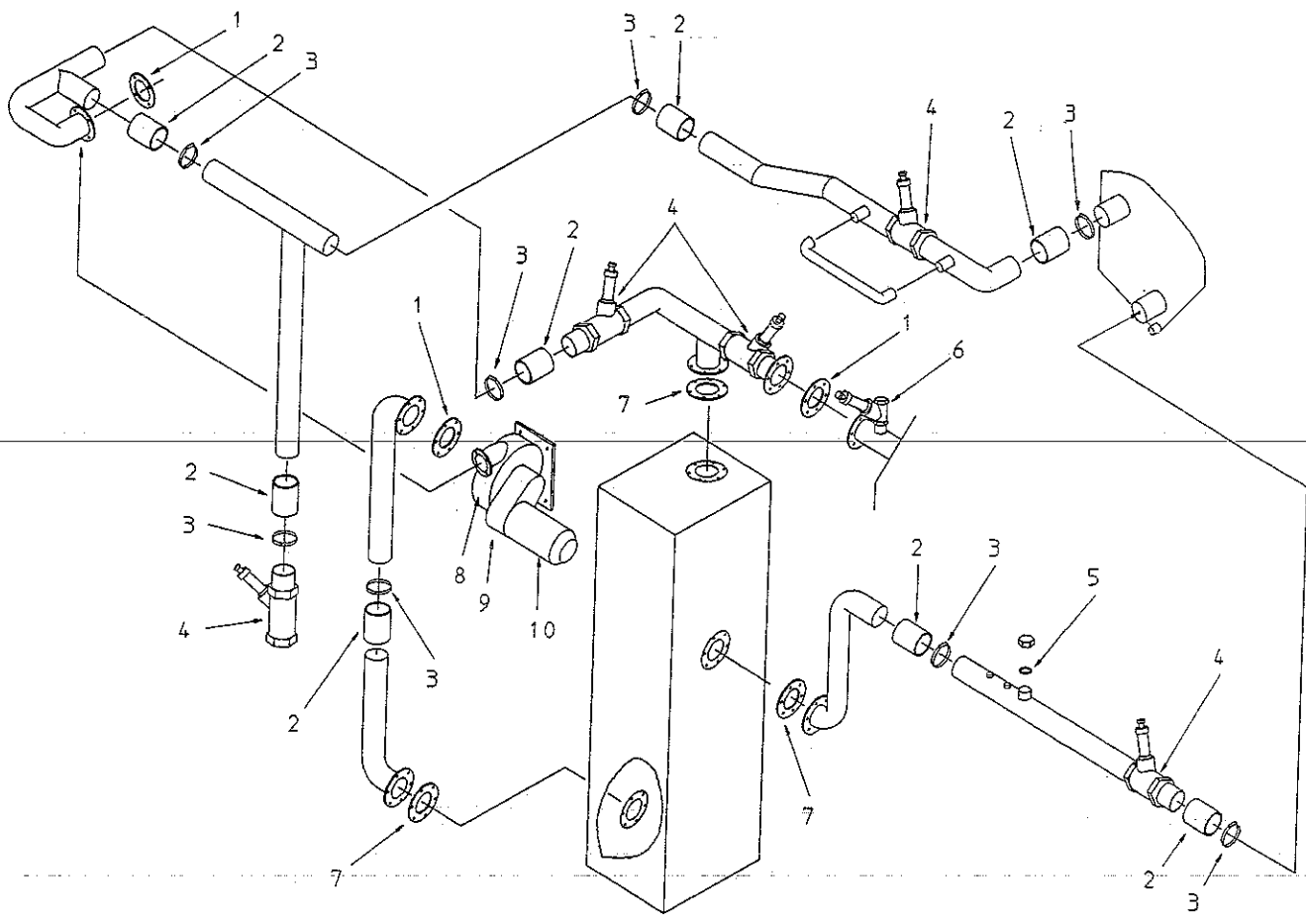

POS. ITEM	BESTELLNUMMER PART NUMBER	BENENNUNG DESIGNATION	POS. ITEM	BESTELLNUMMER PART NUMBER	BENENNUNG DESIGNATION
1	* 700639	KÄLTEAGGREGAT KOMPLETT 400 V - 50 HZ REFRIGERATION UNIT COMPL	16	126231	KAPILLARROHR CAPILLARY TUBE
	700640	KÄLTEAGGREGAT KOMPLETT 230 V - 50 HZ REFRIGERATION UNIT COMPL	17	195371	ABSPERRVENTIL CHECK VALVE
2	148589	RUNDDICHTRING GASKET	18	195408	ABSPERRVENTIL CHECK VALVE
3	200266	VENTILOBERTEIL HEAD FOR VALVE	19	115648	REGLER PRESSOSTAT PRESS. CONTR. SWITCH
4	195218	VENTILGEHÄUSE HOUSING FOR VALVE	20	115646	REGLER PRESSOSTAT PRESS. CONTR. SWITCH
	195421	DÜSE E-VENTIL NR. 4 NOZZLE	21	206849	KOMPRESSOR 400 V - 50 HZ COMPRESSOR
5	193855	SPULE MAGNETVENTIL COIL		206851	KOMPRESSOR 230 V - 50 HZ COMPRESSOR
	193722	MAGNETVENTIL VALVE			KOMPRESSOR 230 V - 60 HZ MT 125 HU3 COMPRESSOR
6	191116	MAGNETVENTIL VALVE	22	200609	TEMPERATURSENSOR THERMAL SENSOR
	193855	SPULE MAGNETVENTIL COIL	24	144737	ABSPERRVENTIL CHECK VALVE
7	026227	T-STÜCK LÖT H T-PIECE	25	191405	BEHÄLTER-SAMMLER CONTAINER
8	195374	SCHAUGLAS SIGHTGLASS	26	137082	VERSCHRAUBUNG UNION
9	148588	RUNDDICHTRING GASKET	27	206852	KONDENSATOR KOAXIAL CONDENSER
10	200265	TROCKNERPATRONE DRYER	28	153589	KLEMMVERSCHRAUBUNG UNION
11	057904	ÜBERWURFMUTTER NUT	29	195201	KONDENSATOR KOAXIAL CONDENSER
12	018618	WÄRMETAUSCHER HEAT EXCHANGER	30	193851	KÜHLWASSERREGLER COOLING WATER REGULATOR
13	026216	LÖTNIPPEL NIPPLE	31	045650	SCHELLE 16 - 25 CLAMP
14	200270	SAUGMANOMETER PRESSURE GAUGE	32	195217	VENTILGEHÄUSE HOUSING FOR VALVE
15	200285	DRUCKMANOMETER PRESSURE GAUGE		195420	DÜSE E-VENTIL NR. 3 NOZZLE

KÄLTEMITTEL R22
REFRIGERATION AID R22

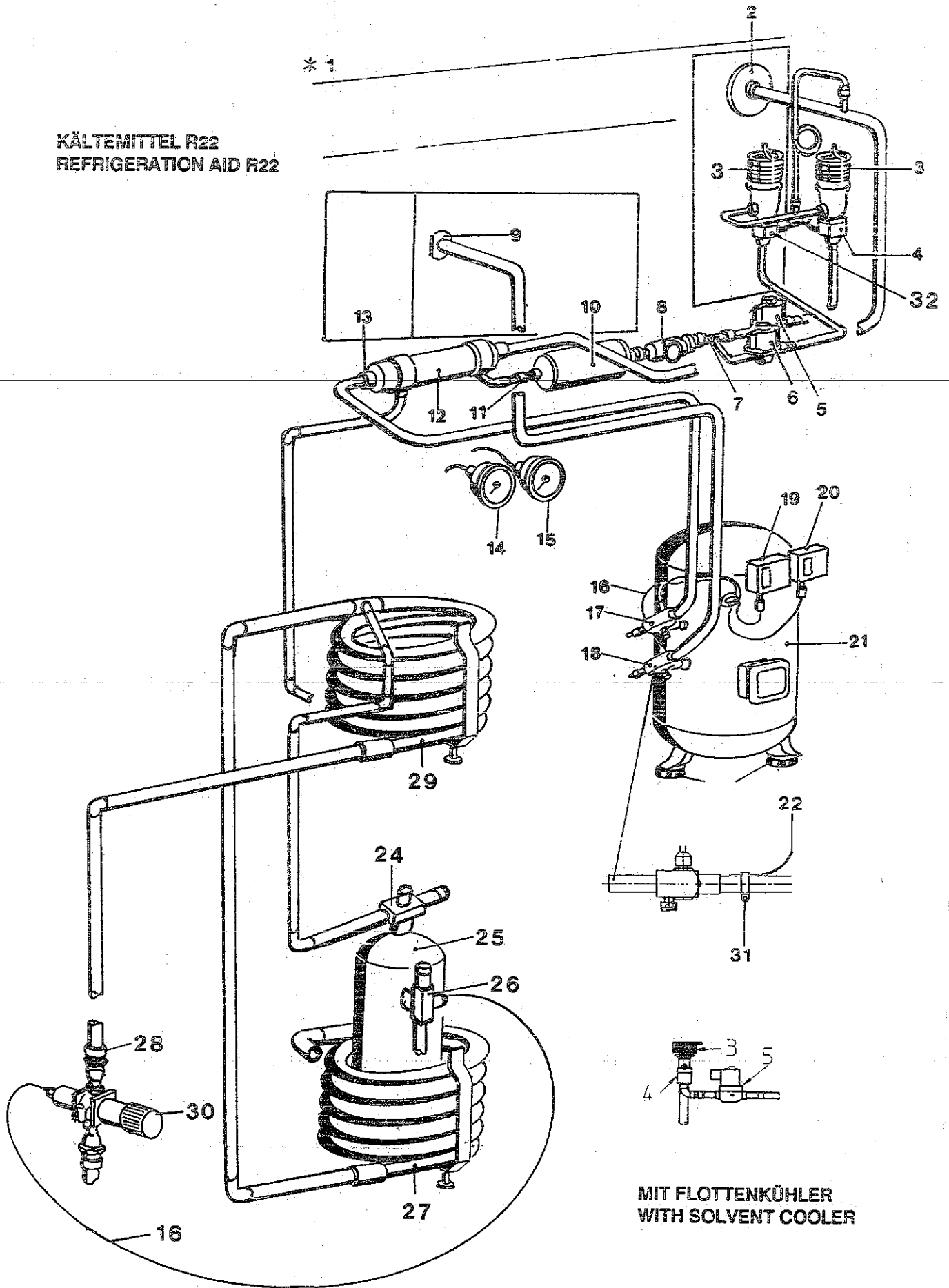

MIT FLOTTENKÜHLER
WITH SOLVENT COOLER

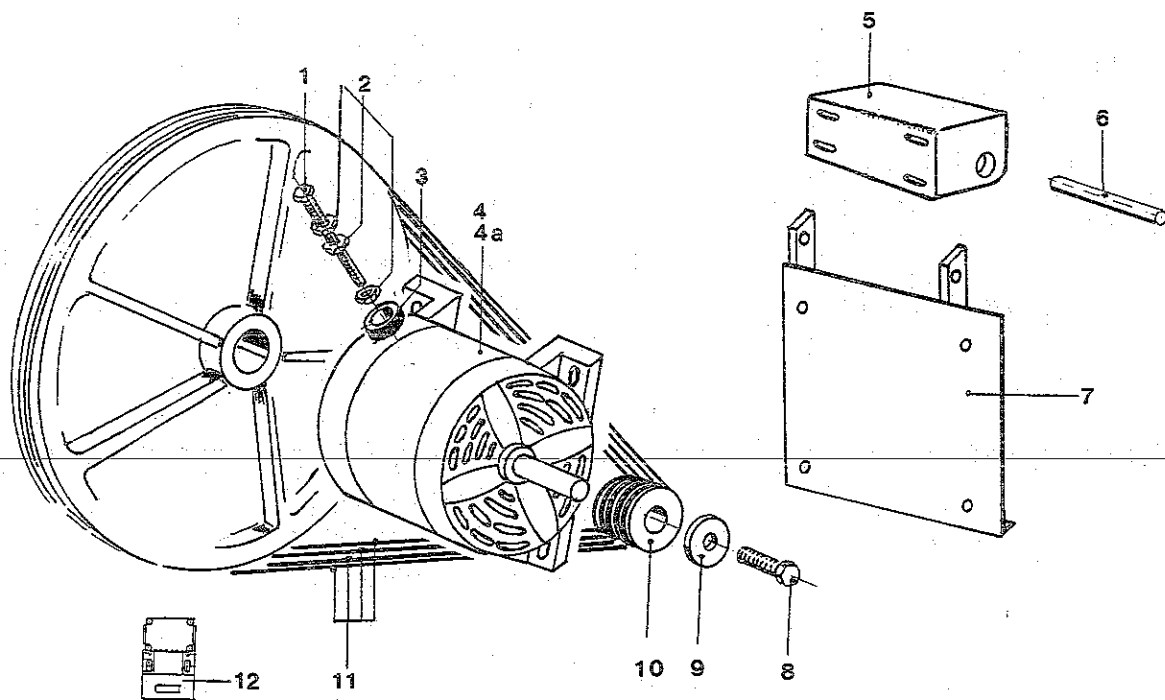

POS. ITEM	BESTELLNUMMER PART NUMBER	BENENNUNG DESIGNATION
1	003162	SCHRAUBE 6KT. M10 X 75 SCREW
2	003818	MUTTER 6KT. M10 NUT
3	086390	GUMMIPUFFER BUFFER
4	203902	ANTRIEBSMOTOR 400 V - 50 HZ DRIVE MOTOR
	203909	ANTRIEBSMOTOR 230 V - 50 HZ DRIVE MOTOR
4a	700322	MOTOR-REGELANTRIEB 230 /400 V, 50 HZ MOTOR VARIABLE SPEED DRIVE
5	203842	MOTORKONSOLE CONSOLE
6	203867	BOLZEN BOLT
7	203854	MOTORAUFHÄNGUNG CONSOLE
8	003887	SCHRAUBE 6KT. SCREW
9	159353	SCHEIBE DISC
10	203720	KEILRIEMENSCHLEIBE V-BELT PULLEY
11	195304	KEILRIEMEN (4 STÜCK) V-BELT (4 PIECE)
12	195409	SCHALTER SWITCH

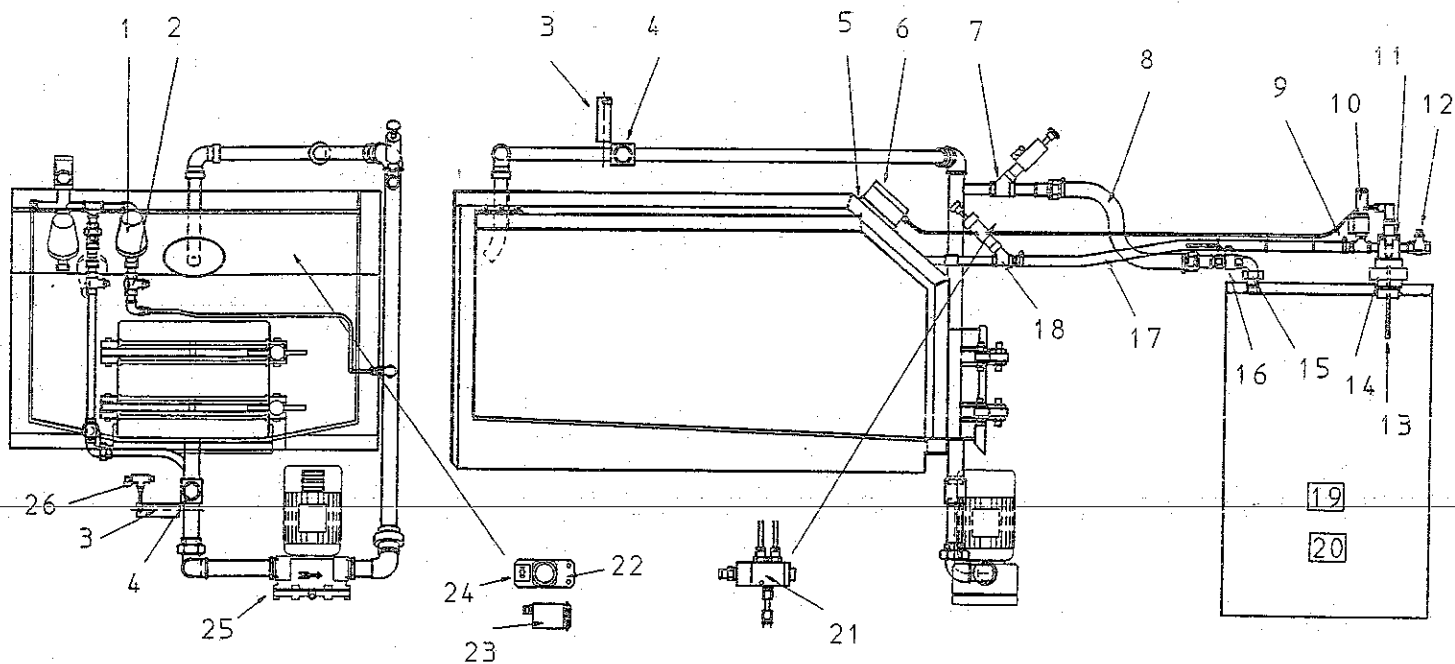

POS. ITEM	BESTELLNUMMER PART NUMBER	BENENNUNG DESIGNATION	POS. ITEM	BESTELLNUMMER PART NUMBER	BENENNUNG DESIGNATION
1	031887	STEUERVENTIL DAMPF 1/2" STEAM VALVE	14	002902	VERSCHRAUBUNG I/A-KOND. DIC UNION
2	125677	RÜCKSCHLAGVENTIL 1/2" CHECK VALVE	15	127971	WINKELVERSCHRAUBUNG A/A ANGLE UNION
3	031865	PRESSLUFTZYLINDER PNEUMATIC RAM	16	116328	KUGELHAHN BALL-COCK VALVE
4	031872	SCHNELLSCHL-SCHIEBER 1 1/4" LEVER GATE VALVE	17	032592	PERBUNAN N SCHLAUCH HOSE
5	126843	HALTEBLECH HOLDING METAL	18	013543	SCHRÄGSITZVENTIL 1/2" SLANTED SEAT VALVE
6	159058	KAPAZITIVSCHALTGERÄT CAPACITIVE CONTROL GEAR	19	196165	DB ENTSORGUNGSFASS 100 L BARREL
7	109850	SCHRÄGSITZVENTIL 3/4" SLANTED SEAT VALVE	20	196166	DB ENTSORGUNGSFASS 200 L BARREL
8	700257	SCHLAUCH 1 M HOSE	21	121261	3/2 WEGE-VENTIL 3/2 WAY VALVE
9	129991	SHELLE CLAMP	22	127699	HALTERUNG HOLDER
10	166351	SICHERHEITSENTIL 0,3 BAR SAFETY VALVE	23	095885	DRUCKTASTER BUTTON
11	025237	ENTLÜFTUNGSROHRLEITUNG TUBE (AERATING)	24	209319	SCHILD DAMPFSTOSS LABEL STEAM INJECTION
12	031917	RÜCKSCHLAGVENTIL 1/2", 0,1 BAR CHECK VALVE	25	144117	PUMPE MIT MOTOR 230 /400 V, 50 HZ PUMP
13	144922	NIVEAUSONDE LEVEL SENSOR	26	053073	DOPPELRÜCKSCHLAGVENTIL DOUBLE CHECK VALVE
	198413	NIVEAUSONDE KOMPLETT LEVEL SENSOR COMPLETE			

DG

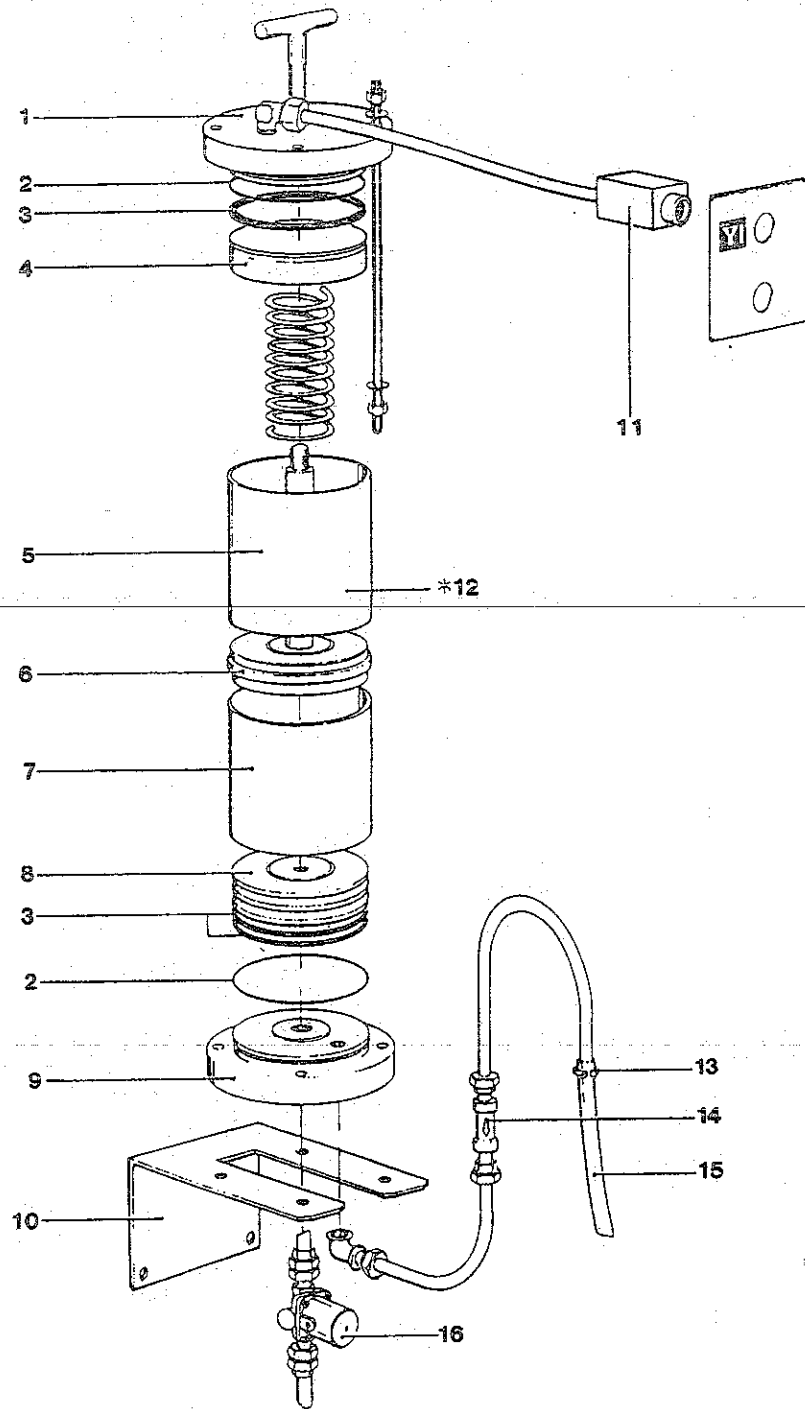

POS. ITEM	BESTELLNUMMER PART NUMBER	BENENNUNG DESIGNATION
1	149292	FLANSCH DECKEL FLANGE LID
2	149368	O-RING 78 X 2 O-RING
3	149369	K-NUTRING K-PACKING RING
4	149365	KOLBEN ANDRUCK PISTON PRESSURE
5	149294	HÜLSE DRUCKLUFT 76 X 80 BUSH COMPRESSED AIR
6	149367	ZWISCHENPLATTE INTERMEDIATE PLATE
7	149293	HÜLSE PRODUKT 76 X 80 BUSH PRODUCT
8	149366	KOLBEN PRODUKT PISTON PRODUCT

POS. ITEM	BESTELLNUMMER PART NUMBER	BENENNUNG DESIGNATION
9	149291	FLANSCH BODEN FLANGE BASE
10	160751	KONSOLE CONSOLE
11	095885	DRUCKTASTER BUTTON
12	* 148077	DOSIERGERÄT DOSING UNIT
13	013024	SCHLAUSCHELLE HOSE CLAMP
14	143002	RÜCKSCHLAGVENTIL R 3/8" CHECK VALVE
15	001795	SCHLAUCH 12 X 2 X 1300 LG HOSE
16	116962	DURCHGANGSVENTIL R 3/8" THROUGH-WAY VALVE

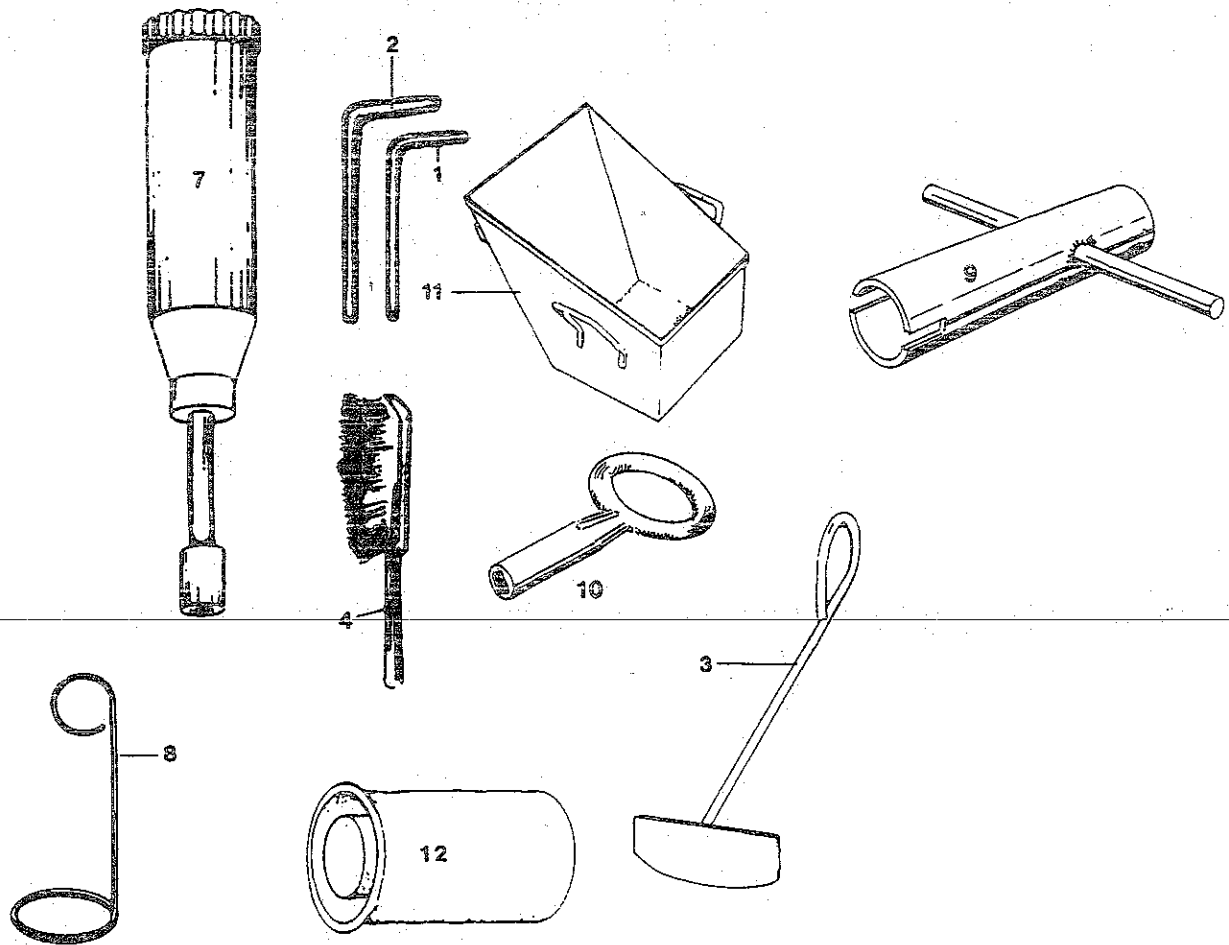

POS. ITEM	BESTELLNUMMER PART NUMBER	BENENNUNG DESIGNATION
1	002018	SECHSKANTSCHLÜSSEL 5 mm HEXAGON WRENCH
	002019	SECHSKANTSCHLÜSSEL 6 mm HEXAGON WRENCH
3	026417	KRATZER SCRAPER
4	032551	STIELBÜRSTE BRUSH
7	080881	FETTPRESSE GREASE GUN
8	028351	EINSCHUBBÜGEL PUSH-IN TOOL

POS. ITEM	BESTELLNUMMER PART NUMBER	BENENNUNG DESIGNATION
9	122679	STECKSCHLÜSSEL FÜR LADETÜRE INSERT KEY
10	160702	STECKSCHÜSSEL FÜR SCHALTSCHRANK INSERT KEY
11	195313	AUSRÄUMWANNE CLEAN-OUT THROUGH
12	207284	FLUSENFILTER-TUCH LINT FILTER STRAINING CLOTH
	148236	INDIKATORPAPIER INDICATOR PAPER
	148324	REGENERIERPULVER REGENERATING POWDER

WARTUNGSEINHEIT

MAINTENANCE UNIT

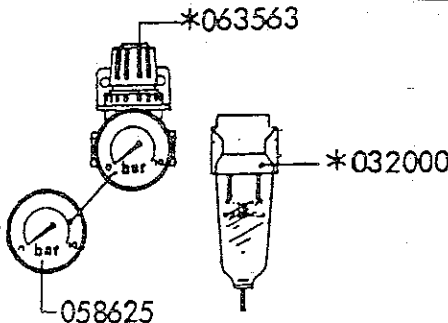
	032000	Filterabscheider kompl. Separator compl.	1/4"
	058625	Röhrenfeder-Manometer Tubular pressure gauge	1/4"
	063563	Druckregelventil kompl. Pressure control valve compl.	1/4"

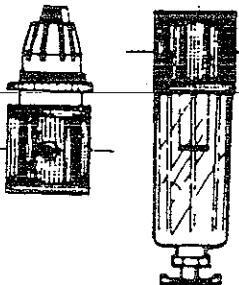

AIRCITY

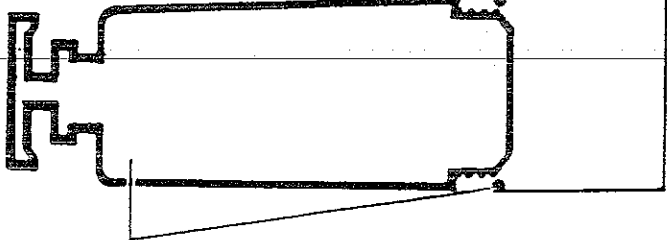

122882

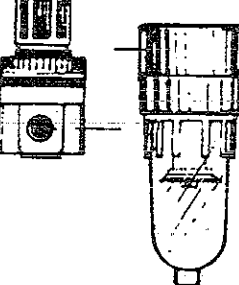

SMC

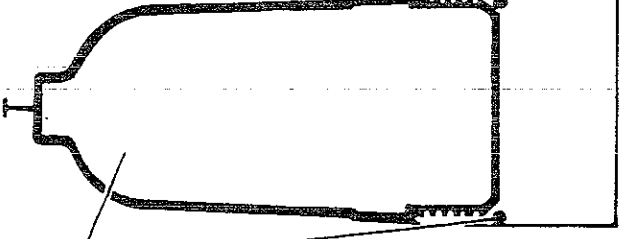

122880

BESTELLNUMMER PART NUMBER	BENENNUNG DESIGNATION
------------------------------	--------------------------

032000	FILTERABSCHIEDER KOMPL 1/4" FILTER SEPARATOR COMPL
058625	RÖHRENFEDER-MANOMETER 1/4" TUBULAR PRESSURE GAUGE
063563	LUFTVENTIL KOMPL 1/4" PRESSURE CONTROL VALVE COMPL
122880	ET-PAKETE FÜR FILTERABSCHIEDER FA. SMC SPARES PACKAGE FOR FILTER SEPARATOR MESSRS. SMC
122882	ET-PAKETE FÜR FILTERABSCHIEDER FA. AIRCITY SPARES PACKAGE FOR FILTER SEPARATOR MESSRS. AIRCITY

KÜHLWASSERREGLER

COOLING WATER REGULATOR

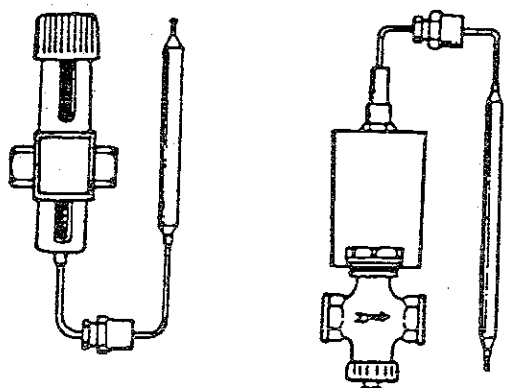

1/2 "	3/4 "	1 "		
* 091613	* 091614	* 091615		

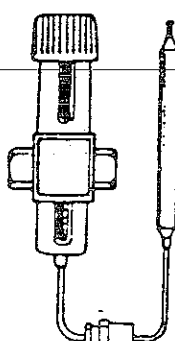

DANFOSS

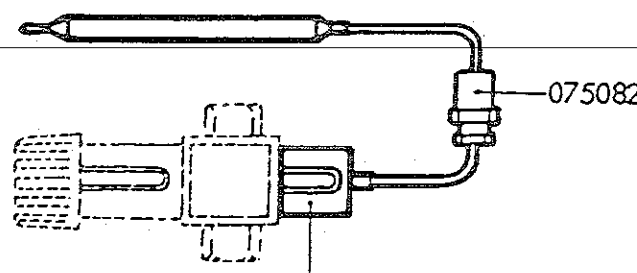

1/2 "	3/4 "	1 "		
103340				

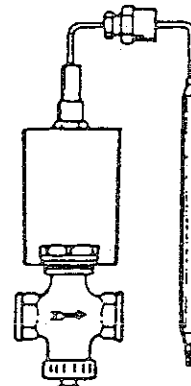

HERION

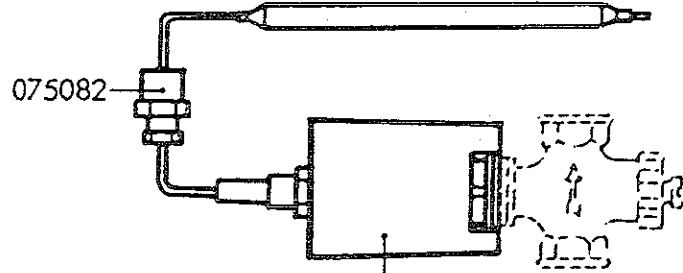

1/2 "	3/4 "	1 "		
148573				

- 075082 DICHTUNGSSATZ
 SET OF GASKET
- 091613 KÜHLWASSERREGLER KOMPL 1/2"
 COOLING WATER REGULATOR KOMPL.
- 091614 KÜHLWASSERREGLER KOMPL 3/4"
 COOLING WATER REGULATOR KOMPL.
- 091615 KÜHLWASSERREGLER KOMPL 1"
 COOLING WATER REGULATOR KOMPL.
- 103340 THERMOKAPSEL FA. DANFOSS
 THERMOCAPSALE DANFOSS
- 148573 THERMOKAPSEL FA. HERION
 THERMOCAPSALE HERION

BESTELLNUMMER PART NUMBER	BENENNUNG DESIGNATION
------------------------------	--------------------------

116962	DURCHGANGSVENTIL KOMPL 3/8" THROUGH-WAY VALVE COMPL
116976	DURCHGANGSVENTIL KOMPL NW 1 mm 1/8" THROUGH-WAY VALVE COMPL
116977	ET-PAKET FÜR BÜRKERT-VENTIL 3/8" SPARES PACKAGE FOR BÜRKERT VALVE
116978	ET-PAKET FÜR MÜLLER-VENTIL 3/8" SPARES PACKAGE FOR MÜLLER VALVE
118524	ET-PAKET FÜR HERION-VENTIL 1/8" SPARES PACKAGE FOR HERION VALVE
123483	ET-PAKET FÜR SUCOMA-VENTIL 1/8" SPARES PACKAGE FOR SUCOMA VALVE
144923	DURCHGANGSVENTIL KOMPL NW 2,4 mm 1/8" TROUGH-WAY VALVE COMPL

DURCHGANGSVENTIL

VALVE

DURCHGANGSVENTIL

VALVE

3/8" SN 116962

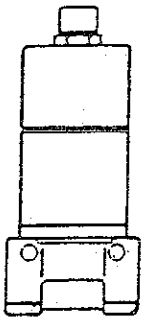

BÜRKERT

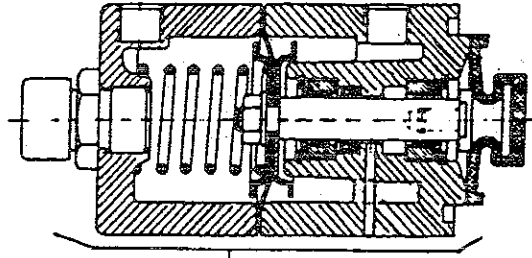

3/8"				
116977				

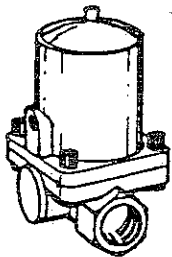

MÜLLER

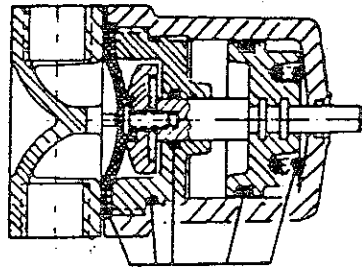

3/8"				
116978				

DURCHGANGSVENTIL

VALVE

1/8" SN 116976

1/8" SN 144923

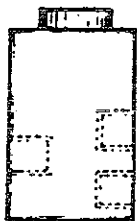

SUCOMA

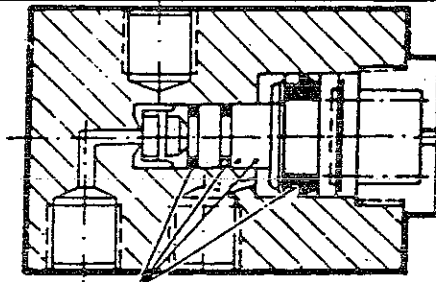

1/8"				
123483				

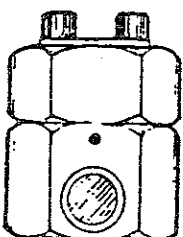

HERION

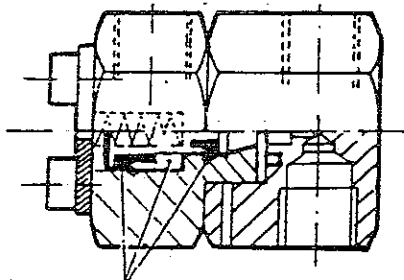

1/8"				
118524				

DAMPFVENTIL

STEAM VALVE

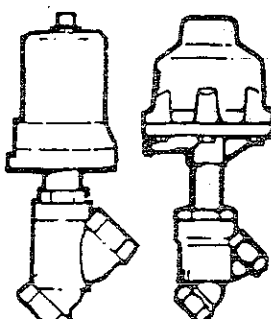

1/2"		1"	1 1/2"	2"
* 031887				

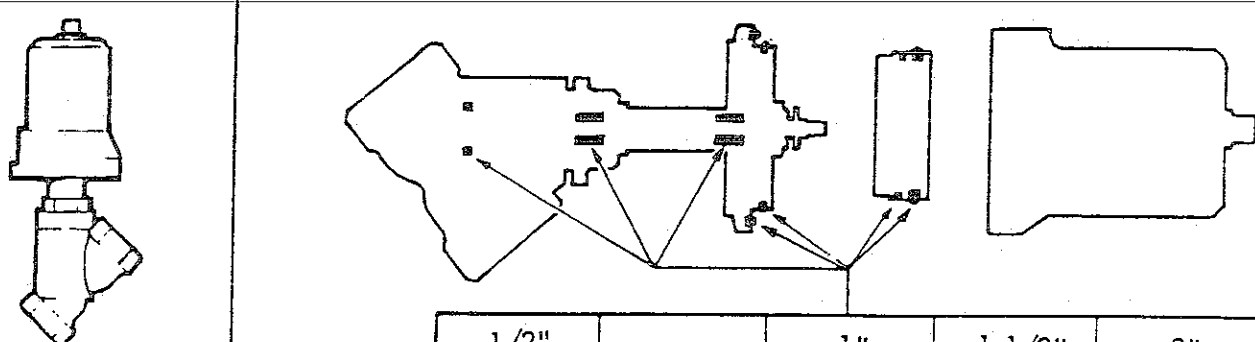

BÜRKERT

1/2"		1"	1 1/2"	2"
085266				

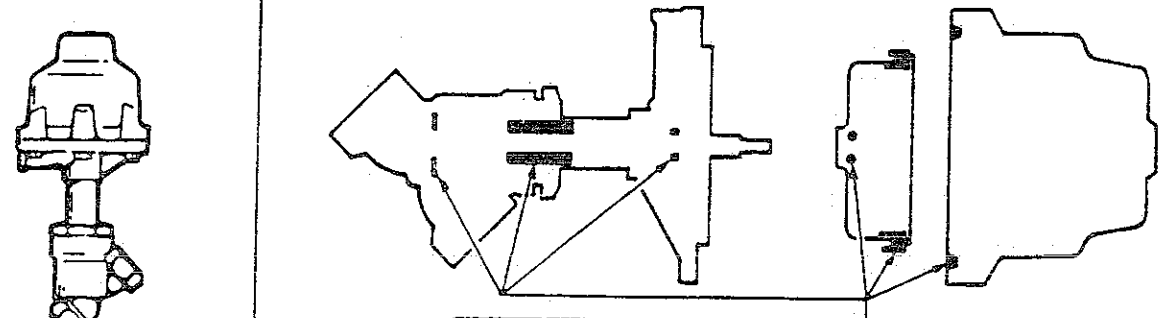

GEMÜ

1/2"				
085296				

BESTELLNUMMER
PART NUMBER

BENENNUNG
DESIGNATION

031887

DAMPFVENTIL KOMPL 1/2"
STEAM VALVE COMPL

085266

ET-PAKET FÜR BÜRKERT-VENTIL 1/2"
SPARES PACKAGE FOR BÜRKERT VALVE

085296

ET-PAKET FÜR GEMÜ-VENTIL 1/2"
SPARES PACKAGE FOR GEMÜ VALVE

**SCHRÄGSITZVENTIL
SLANTING-SEAT VALVE**

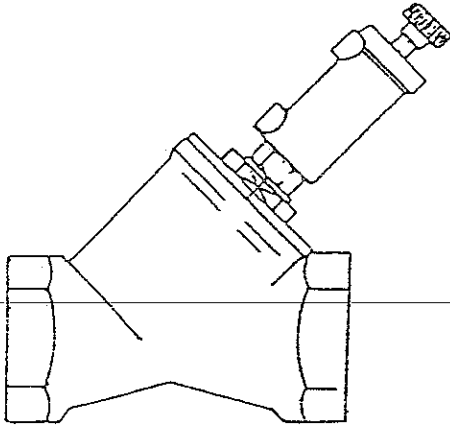

2"	2 1/2"	3"
* 169949	* 166722	* 166721
		*205638

2"	2 1/2"	3"
193803	193804	193805

**ET-PAKET
SPARES-PACKAGE**

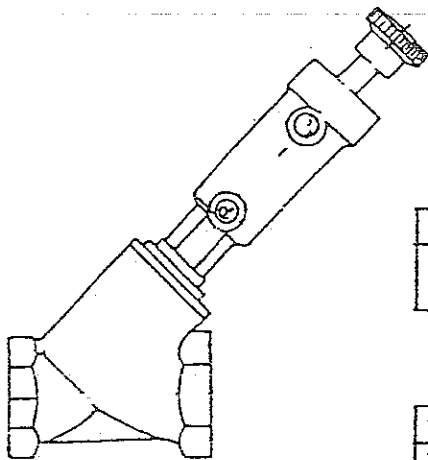

**ET-PAKET
SPARES-PACKAGE**

1/2"	3/4"	1"	1 1/4"	1 1/2"	2"
* 013543 + 161105	*109850	*139407	*109851 *197698	*164226 *202494	*161310

1/2"	3/4"	1"	1 1/4"	1 1/2"	2"
195975	195976	195977	196044	190949	190944



MAGNETVENTIL

SOLENOID VALVE

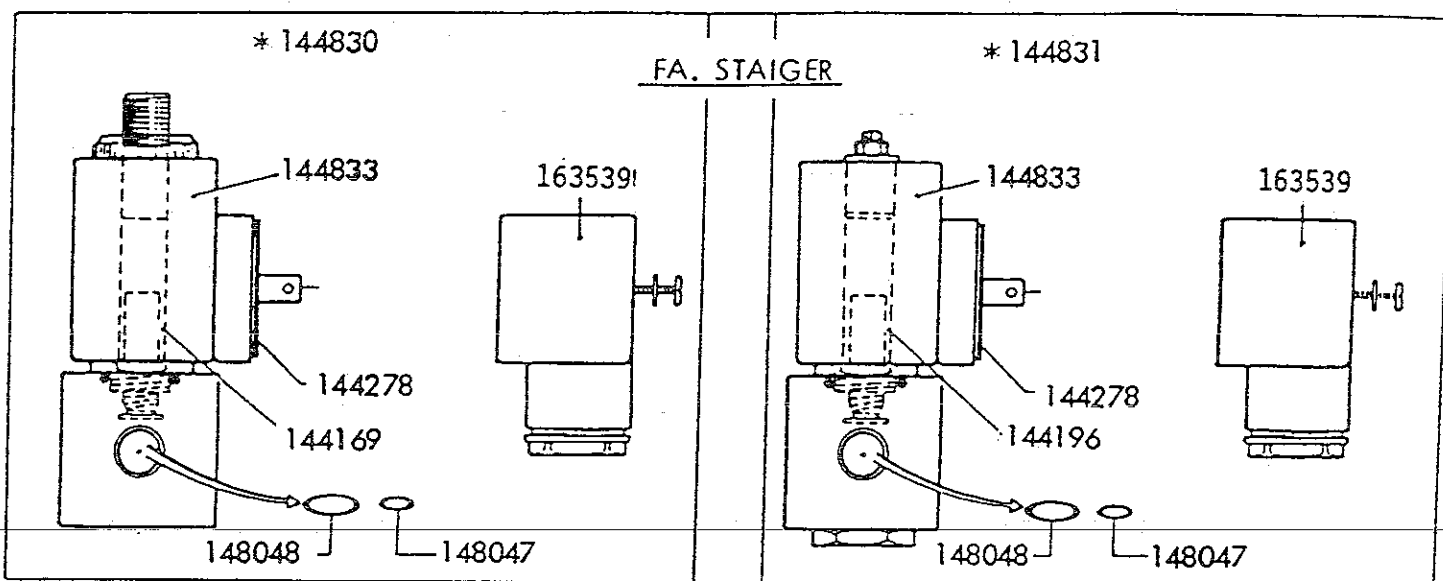

BESTELLNUMMER
PART NUMBER

BENENNUNG
DESIGNATION

144169	PLUNGER KOMPL. STROMLOS GESCHLOSSEN PLUNGER COMPL. CLOSED WITHOUT CURRENT
144196	PLUNGER KOMPL. STROMLOS GEÖFFNET PLUNGER COMPL. OPEN WITHOUT CURRENT
144278	DICHTUNG GASKET
144830	MAGNETVENTIL STROMLOS GESCHLOSSEN 24 V GLEICHSTROM SOLENOID VALVE CLOSED WITHOUT CURRENT 24 V DIRECT CURRENT
144831	MAGNETVENTIL STROMLOS GEÖFFNET 24 V GLEICHSTROM SOLENOID VALVE OPEN WITHOUT CURRENT 24 V DIRECT CURRENT
144833	MAGNETSPULE 24 V GLEICHSTROM MAGNET COIL 24 V DIRECT CURRENT
148047	O-RING 7 X 1,5 O-RING
148048	O-RING 14 X 1,5 O-RING
163539	GERÄTESTECKER RECEPTABLE

KONDENSATABLEITER 1/2"
TYP TD52M SPIRAX-SARCO KOMPL.

KONDENSATABLEITER 1/2"
SN 065359

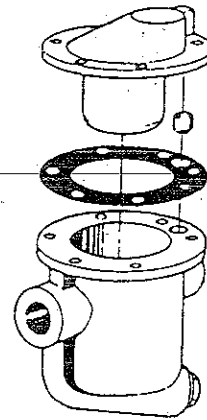
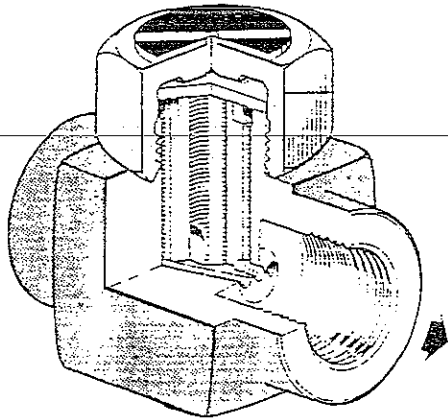

BESTELLNUMMER	BENENNUNG
PART NUMBER	DESIGNATION

109360	KONDENSATABLEITER 1/2" TYP TD52M SPIRAX-SARCO KOMPL. STEAM TRAP 1/2" TYPE TD52M SPIRAX-SARCO COMPL.
165287	BYMETALL-ELEMENT BIMETAL ELEMENT
065359	KONDENSATABLEITER 1/2" STEAM TRAP
109361	KONDENSATABLEITER 3/4" STEAM TRAP

		3/4"	1"	1 1/2"	2"	2 1/2"
 I Dollinger Rumbucher	 II Kemper			045576	045575	
				056454		
		I	II	I	II	
A						
B						
C						
 III		III	III			
		126241	109865			
A						
B						

 115637	 129238	 163605 1 1/4"
------------	------------	-------------------

PRESSLUFTZYLINDER

PNEUMATIC RAM

 KNORR	 PERMAC	3/4" - 1"	1 1/4" - 1 1/2"	2"	2 1/2"
				KNORR PERMAC	KNORR PERMAC
			031865 25/36		031863 35/66
A					
B					142035
C					142036
D					

- 126241 SCHAUGLAS KOMPLETT 3/4" SIGHT-GLASS COMPLETE
- 109865 SCHAUGLAS KOMPLETT 1" SIGHT-GLASS COMPLETE
- 163605 SCHAUGLAS KOMPLETT 1 1/4" SIGHT-GLASS COMPLETE
- 045576 SCHAUGLAS KOMPLETT 1 1/2" SIGHT-GLASS COMPLETE
- 056454 SCHAUGLAS KOMPLETT 1 1/2" SIGHT-GLASS COMPLETE
- 045575 SCHAUGLAS KOMPLETT 2" SIGHT-GLASS COMPLETE
- 115637 GLÜHLAMPE 24 V 3 W BULB
- 129238 STECKFASSUNG SOCKET

- 031865 PRESSLUFTZYLINDER 1 1/4" PNEUMATIC RAM
- 031863 PRESSLUFTZYLINDER KOMPL. 2 1/2" PNEUMATIC RAM
- 205721 PRESSLUFTZYLINDER MARTONAIR RM 8032/160 PNEUMATIC RAM
- 031878 PRESSLUFTZYLINDER DRUMAG ZLA-S-50 /60 D PNEUMATIC RAM
- 115661 ET-PAKET DRUMAG-ZYLINDER SPARE PACKAGE FOR DRUMAG RAM
- 142035 ET-PAKET FÜR KNORR-ZYLINDER 35/66 ET-SPARES FOR KNORR RAM 35/66
- 142036 ET-PAKET FÜR PERMAC-ZYLINDER 35/66 ET-SPARES FOR PERMAC RAM 35/66

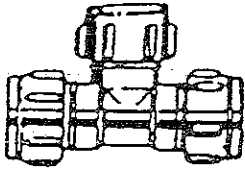

Verschraubung T-Stück
T iron

22 x 22 x 22	SN 155759
28 x 28 x 28	SN 155760
42 x 42 x 42	SN 160830
35 x 35 x 35	SN 163702

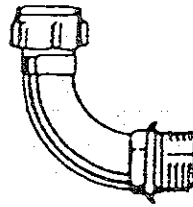

Einschraubbogen
Threaded elbow

18 x 1/2"	SN 156628
22 x 3/4"	SN 155743
28 x 1"	SN 155744
35 x 1 1/4"	SN 163828

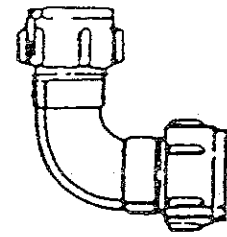

Bogen
Elbow

22 x 22	SN 155717
28 x 28	SN 155718
35 x 35	SN 163704

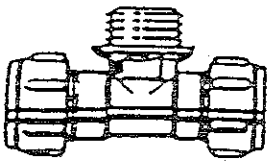

Einschraub-T-Stück
Threaded T iron

22 x 1/2" x 22	SN 155766
22 x 3/4" x 22	SN 155767
28 x 1" x 28	SN 155854

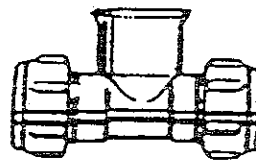

Muffen-T-Stück
Sleeve iron

28 x 3/4" x 28	SN 155772
28 x 1/2" x 28	SN 161249



Gerade Verschraubung
Straight union

15 x 15	SN 156554
12 x 12	SN 161388
18 x 18	SN 153578
22 x 22	SN 153580
28 x 22	SN 153581
28 x 28	SN 153582
42 x 42	SN 160765
54 x 54	SN 160764

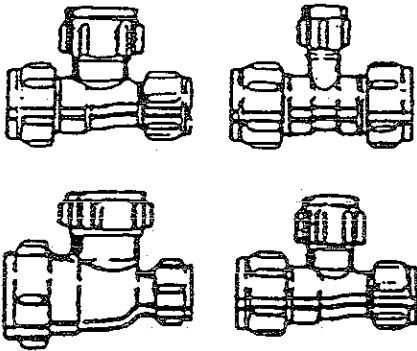

Reduziertes T-Stück
Reduced T iron

15 x 12 x 15	SN 157853
18 x 18 x 15	SN 156602
18 x 15 x 15	SN 161246
22 x 15 x 22	SN 156629
22 x 28 x 22	SN 157857
28 x 22 x 22	SN 157855
28 x 22 x 28	SN 157856
28 x 28 x 22	SN 157858
28 x 15 x 28	SN 161245
28 x 28 x 15	SN 163701

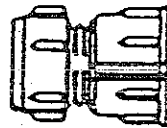

Muffen-Verschraubung
Sleeve union

15 x 1/2"	SN 155687
15 x 3/4"	SN 155688
22 x 1/2"	SN 155691
22 x 3/4"	SN 155692
22 x 1"	SN 155693
28 x 3/4"	SN 155694
28 x 1"	SN 155695

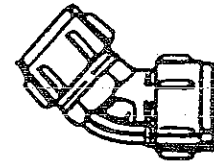

Winkel-Verschraubung 45
Elbow

28 x 28	SN 155714
---------	-----------

KLEMMRING-VERSCHRAUBUNGEN
CLAMPING RING UNIONS

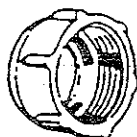

Überwurfmutter
Clamping nut

12	SN 153568
15	SN 153569
18	SN 153570
22	SN 153571
28	SN 153572



Klemmring
Clamping ring

12	SN 153573
15	SN 153574
18	SN 153575
22	SN 153576
28	SN 153577

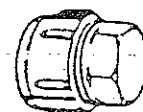

Verschlußstück
Screw cap

12	SN 155697
15	SN 155698
18	SN 155699
22	SN 155701
28	SN 155702

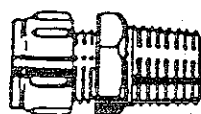

Einschraubverschraubung
kon. Rohrgewinde
Pipe union conical
pipe thread

15 x 1/2"	SN 153595
18 x 1/2"	SN 155681
22 x 3/4"	SN 155683
22 x 1"	SN 155684
28 x 3/4"	SN 155685
28 x 1"	SN 155686

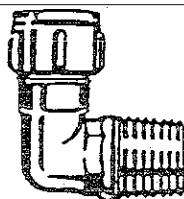

Einschraubwinkel
konisch
Threaded angle
conical

12 x 3/8"	SN 155732
15 x 3/8"	SN 155734
15 x 1/2"	SN 155735
18 x 1/2"	SN 155738
22 x 3/4"	SN 155739
28 x 1"	SN 155741

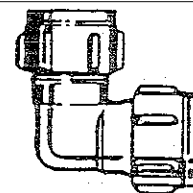

Winkel-Verschraubung
Elbow

12 x 12	SN 155703
15 x 15	SN 155706
18 x 18	SN 155708
22 x 15	SN 155709
22 x 22	SN 155710
28 x 22	SN 155711
28 x 28	SN 155712
28 x 15	SN 163777



Einschraub-
verschraubung
Pipe union

10 x 1/2"	SN 161250
12 x 3/8"	SN 153583
12 x 1/2"	SN 153584
15 x 3/8"	SN 153585
15 x 1/2"	SN 153586
18 x 1/2"	SN 153587
18 x 3/4"	SN 156601
22 x 1/2"	SN 153588
22 x 3/4"	SN 153589
28 x 1"	SN 153590
28 x 3/4"	SN 153591
28 x 1"	SN 153592
42 x 1 1/2"	SN 160763
35 x 1"	SN 163703
35 x 1 1/4"	SN 163755

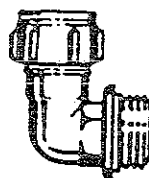

Einschraubwinkel
Threaded angle

12 x 3/8"	SN 155719
12 x 1/2"	SN 155720
15 x 3/8"	SN 155721
15 x 1/2"	SN 155722
18 x 1/2"	SN 155724
22 x 1/2"	SN 155726
22 x 3/4"	SN 155727
28 x 3/4"	SN 155729
28 x 1"	SN 155730
35 x 1 1/4"	SN 163699

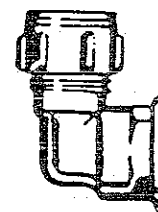

Muffenwinkel
Sleeve angle

15 x 1/2"	SN 155748
18 x 1/2"	SN 155750
22 x 1/2"	SN 155752
22 x 3/4"	SN 155753
22 x 1"	SN 155754
28 x 3/4"	SN 155755
28 x 1"	SN 155756
35 x 1 1/4"	SN 163700

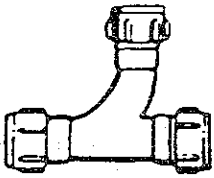

T-Stück mit einem gebogenen Abzweig
T iron with curved branch

22 x 22 x 22 SN 155762
28 x 28 x 28 SN 155763
35 x 35 x 35 SN 163829



Muffen-Verschraubung mit kurzem Innengewinde
Sleeve union with short inside thread

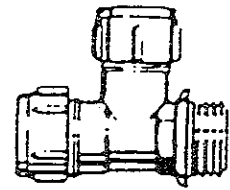

Einschraub-T-Stück
Threaded iron

15 x 15 x 1/2" SN 155774
22 x 22 x 3/4" SN 155775
22 x 22 x 1" SN 155776

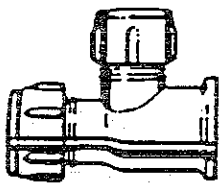

Muffen-T-Stück
Sleeve iron

22 x 22 x 1/2" SN 155778
28 x 28 x 1/2" SN 161244
28 x 28 x 1" SN 155902

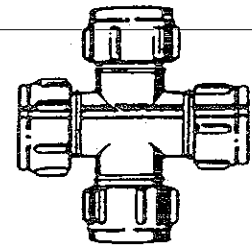

Kreuzstück
Crosspiece

22 x 22 x 22 x 22 SN 155903
28 x 28 x 28 x 28 SN 163773

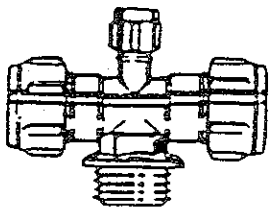

Einschraub-T-Stück
Threaded T iron

22 x 3/4" x 1/8" SN 157912

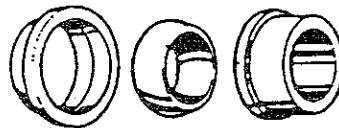

Reduzierringe
Reducing washers

28 x 22 SN 160837

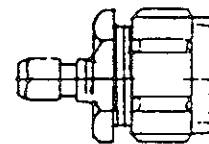

Gerade Verschraubung
Straight union

22 x 1/8" SN 157911

